



## *Maryland Motor Carrier Handbook*

*Revised October 2011*

*In Cooperation with :*

- ❖ *Comptroller of Maryland*
- ❖ *Maryland State Police*
- ❖ *Maryland Port Administration*
- ❖ *Motor Vehicle Administration*
- ❖ *Maryland Department of the Environment*
- ❖ *Public Service Commission*
- ❖ *Maryland Transportation Authority*
- ❖ *Maryland Department of Transportation – Office of Freight & Multimodalism*



## Disclaimer:

Information contained in the Handbook regarding the various laws and regulations governing commercial motor vehicle operations in Maryland are subject to change without notice. The Handbook is produced solely as a convenience to the public. The State assumes no warranty or representation, either expressed or implied, regarding the information given or the use of any of the material provided or for unintentional omissions, errors, or misprints which appear herein.

## Maryland Motor Carrier Handbook Survey

1. What do you like about the Handbook?

---

---

---

2. What don't you like about the Handbook?

---

---

---

3. Is there any information you did not see in the Handbook that you would like to see included in future editions?

---

---

---

4. Did the Handbook help you in understanding the regulations? Please check one.

\_\_\_\_\_Yes                      \_\_\_\_\_No

5. Was the material. Please check one.

\_\_\_\_\_ Too long?                      \_\_\_\_\_ Just right?

6. In your opinion what else could be provided in the Handbook?

---

---

---

Thank you for taking time to provide us with your comments!

IMPORTANT: DO NOT ENLARGE, REDUCE OR MOVE the FIM and POSTNET barcodes. They are only valid as printed.  
Postage paid and postage meter use are not permitted. Actual size AND placed properly on the mail piece  
to meet both USPS regulations and automation compatibility standards.



NO POSTAGE  
NECESSARY  
IF MAILED  
IN THE  
UNITED STATES

**BUSINESS REPLY MAIL**

FIRST-CLASS MAIL PERMIT NO. 17715 BALTIMORE MD

POSTAGE WILL BE PAID BY ADDRESSEE

**ROOM 111**  
OFFICE OF TRAFFIC AND SAFETY  
MOTOR CARRIER DIVISION  
MD DEPT OF TRANSPORTATION  
STATE HIGHWAY ADMINISTRATION  
707 NORTH CALVERT STREET  
BALTIMORE MARYLAND 21298-6216



Workset for User Defined (5.25" x 8.25")  
Layout: C:\Program Files\Envigo\gr320\datzdz632v4.375 X 5.75LVT  
March 4, 2009 05:02:50

Produced by DAZZLE Designer 2002, Version 4.3.08  
(c) Envelope Manager Software, www.EnvelopeManager.com, (800) 576-5279  
U.S. Postal Service, Serial #110

## A MESSAGE FROM THE DIRECTOR OF THE STATE HIGHWAY ADMINISTRATION'S OFFICE OF TRAFFIC AND SAFETY

This latest edition of the "*Maryland Motor Carrier Handbook*," marks the 21<sup>st</sup> year since the first Handbook "*Trucking in Maryland*" was introduced. For twenty-one years, the Handbook has been a valuable resource guide for the motor carrier industry and others who seek to learn more about Maryland's laws and regulations pertaining to truck and bus operations. We hope that you find the information useful to your operations as it covers both the Federal regulations and Maryland laws and regulations for commercial vehicle operations. This information should not be used in lieu of the law.

SHA reminds you to drive responsibly and share the road with others who are using our highway system. Put safety at the top of your list and make it a part of your daily operations. Do the right thing and "Choose Safety For Life." When driving, stay alert for the unexpected and maintain a safe distance between your vehicle and the one in front of you. Avoid sudden stops and hard braking as these actions could cause you to lose control of your vehicle.

The Handbook is produced by our Motor Carrier Division and we welcome your suggestions on how it may be improved. For your convenience, we have included a postage paid, self-addressed detachable survey card prior to this page. Please take a few moments to fill it out and return it to us. If you prefer to speak to someone in the Motor Carrier Division about the Handbook, please call them at 410-582-5734 or toll-free at 1-800-543-4564.

As a commercial vehicle driver, sending or reading text messages as well as talking on a hand-held cellular telephone while driving in Maryland is against the law. Buckle Up, drive responsibly and enjoy our great State!

Thomas Hicks

# Table of Contents

	Page
<u>"UNIFIED CARRIER REGISTRATION ACT"</u>	xiv
COMPLIANCE, SAFETY, ACCOUNTABILITY PROGRAM	xiv
CHANGES IN MARYLAND VEHICLE LAW – WHAT’S NEW	xv
EXCEPTIONAL HAULING PERMIT	xvii

## **CHAPTER I**

<b>INTRODUCTION - GENERAL RULES AND REGULATIONS</b>	1
A. TRUCK IDLING	3
B. QUICK REFERENCE GUIDE – WHO CAN I CONTACT?	4
C. USEFUL WEB PAGE ADDRESSES FOR AGENCIES	6
D. HOMELAND SECURITY - PROTECTING AMERICA AND MARYLAND	7
E. FREQUENTLY ASKED QUESTIONS	8

## **CHAPTER II**

<b>MARYLAND TRUCK ROUTE SYSTEM</b>	18
------------------------------------	----

## **CHAPTER III**

<b>TRUCK PARKING</b>	
A. TRUCK WEIGH AND INSPECTION STATIONS (TWIS)	21
B. MARYLAND WELCOME CENTERS	22
C. PRIVATE TRUCK STOPS	24

## **CHAPTER IV**

<b>REGISTERING YOUR VEHICLE</b>	27
A. GETTING STARTED	27
B. TITLES AND REGISTRATION	28
C. FEDERAL HEAVY VEHICLE USE TAX (HVUT)	30
D. PREVENTIVE MAINTENANCE (PM) PROGRAM	31
E. FEES	31
1. PARTIAL YEAR REGISTRATION	31
2. REGISTERING SINGLE UNIT TRUCKS	31
3. REGISTERING DUMP SERVICE VEHICLES	32
4. REGISTERING TRUCK/TRAILER COMBINATIONS	35
5. REGISTERING TRACTOR/TRAILER COMBINATIONS	35
6. REGISTERING FREIGHT TRAILERS	36
7. REGISTERING NON-FREIGHT TRAILERS AND FARM VEHICLES	36

## **CHAPTER V**

<b>INTERNATIONAL REGISTRATION PLAN (IRP) APPORTIONED REGISTRATION</b>	38
---	----

## **CHAPTER VI**

<b>INTERNATIONAL FUEL TAX AGREEMENT (IFTA)</b>	42
--	----

## **CHAPTER VII**

<b>DISPLAY OF VEHICLE IDENTIFICATION</b>	44
A. USDOT NUMBER	44
B. MC NUMBER - OPERATING AUTHORITY	44
C. MARYLAND USDOT NUMBER	45
D. AUTHORITY FROM THE PUBLIC SERVICE COMMISSION (PSC)	46

## **CHAPTER VIII**

<b>DRIVER'S LICENSING - REQUIREMENTS</b>	47
A. GENERAL RULES	47
B. COMMERCIAL DRIVER'S LICENSE (CDL)	48
C. AGE REQUIREMENTS FOR CDL'S	50
D. THE CDL DRIVING TEST	52
E. SPECIAL ENDORSEMENTS FOR CDL'S	55
F. HAZARDOUS MATERIALS (HAZ-MAT) ENDORSEMENT	56
G. THE DRIVER'S RESPONSIBILITY	56
H. NON-COMMERCIAL DRIVER'S LICENSE	57
I. QUESTIONS	59
J. SUSPENSION/REVOICATION/DISQUALIFICATION	59

## **CHAPTER IX**

<b>INSURANCE REQUIREMENTS</b>	61
A. INTRASTATE OPERATIONS	61
1. FOR CARRIERS OF FLAMMABLES	61
2. FOR CARRIERS OF PASSENGERS	61
B. INTERSTATE OPERATIONS	62

## **CHAPTER X**

<b>COMMERCIAL VEHICLE INFORMATION SYSTEMS AND NETWORKS (CVISN)</b>	63
A. CURRENT CVISN APPLICATIONS	64
B. TRANSPONDERS – HOW CAN I PARTICIPATE IN THE PROGRAM?	65
C. CVISN – THE FUTURE	65

## **CHAPTER XI**

<b>SAFE VEHICLE OPERATIONS</b>	66
A. VEHICLE CONTROL	66
B. LOAD SECUREMENT	66
C. BRAKING SYSTEMS – MAINTENANCE & SAFETY	67
D. DISABLED VEHICLES	68

## **CHAPTER XII**

<b>VEHICLE SIZE &amp; LOADS</b>	71
A. MAXIMUM WIDTH – MEASURING – LIMITS EXPLAINED - EXCEPTIONS	71
B. MAXIMUM HEIGHT	72
C. LENGTH – HOW TO MEASURE - EXCEPTIONS	72
1. MAXIMUM LENGTH – SINGLE UNIT VEHICLES	73
2. MAXIMUM LENGTH – COMBINATIONS OF VEHICLES	74
3. SEMI-TRAILERS EXCEEDING 48' IN LENGTH UP TO A LENGTH NOT TO EXCEED 53' – OPERATING RESTRICTIONS	77
4. BUMPER HEIGHTS	78
D. LOAD EXTENSION LIMITS - EXCEPTIONS	79
E. COVERING LOADS	79

## **CHAPTER XIII**

<b>OVERSIZE/OVERWEIGHT HAULING PERMITS</b>	81
A. LEGAL WEIGHTS	81
B. OVERSIZE/OVERWEIGHT HAULING PERMITS	81
C. POSTED HIGHWAY DETOURS	83
D. ESCORT POLICIES	83
E. TOLL FACILITIES – TUNNELS – BRIDGE RESTRICTIONS	84

## **CHAPTER XIV**

<b>MAXIMUM ALLOWABLE VEHICLE &amp; AXLE WEIGHTS</b>	86
A. BRIDGE FORMULA	86
BRIDGE TABLE	88
B. EXAMPLES – HOW TO DETERMINE GROSS VEHICLE WEIGHT AND MULTIPLE AXLE WEIGHTS USING THE BRIDGE FORMULA	89
C. EXCEPTION TO THE BRIDGE FORMULA	93
D. GROSS WEIGHT LIMITATIONS BASED ON THE NUMBER OF AXLES	94
E. WEIGHT ENFORCEMENT PROGRAM	95

## **CHAPTER XV**

<b>MOVEMENT OF HAZARDOUS MATERIALS (HAZ-MAT)</b>	96
A. GENERAL INFORMATION	96
B. SCRAP TIRE HAULERS	96
C. MOTOR FUEL TRANSPORTERS	96
D. BULK PETROLEUM TRANSPORTERS	97
E. HAZ-MAT RELEASE REPORTS	97

## **CHAPTER XVI**

<b>ENVIRONMENTAL ENFORCEMENT PROGRAMS</b>	98
A. DIESEL VEHICLE EMISSIONS CONTROL PROGRAM (DVECP)	98
(1) MARYLAND REGISTERED VEHICLES	99
(2) FOREIGN REGISTERED VEHICLES	99
B. NOISE ABATEMENT PROGRAM	100

## **CHAPTER XVII**

<b>PORT OF BALTIMORE</b>	101
--------------------------	-----

## **CHAPTER XVIII**

<b>TRAFFIC CRASH REPORTING</b>	102
--------------------------------	-----

## **CHAPTER XIX**

<b>MARYLAND MOTOR CARRIER SAFETY PROGRAM</b>	104
A. PURPOSE OF PROGRAM	104
B. PREVENTIVE MAINTENANCE (PM) PROGRAM	105

## **CHAPTER XX**

<b>FEDERAL MOTOR CARRIER SAFETY REGULATIONS</b>	108
A. GENERAL ISSUES	108
B. PART 391 – QUALIFICATIONS OF DRIVERS	109
C. PART 392 – DRIVING COMMERCIAL MOTOR VEHICLES	111
D. PART 393 – PARTS AND ACCESSORIES NECESSARY FOR SAFE OPERATION	112

E. PART 395 – HOURS OF SERVICE FOR DRIVERS	113
F. PART 396 – INSPECTION, REPAIR AND MAINTENANCE	116
G. PART 397 – TRANSPORTATION OF HAZARDOUS MATERIALS - DRIVING AND PARKING RULES	118

## **CHAPTER XXI**

<b>ALCOHOL AND DRUG TESTING REGULATIONS</b>	120
A. WHO MUST BE TESTED	120
B. CONTROLLED SUBSTANCES	120
C. TESTS REQUIRED	121
D. CONSEQUENCES	121
E. ASSISTANCE FOR SMALL CARRIERS AND OWNER-OPERATORS	122
F. ADDITIONAL INFORMATION	122

## **APPENDIX**

A. GLOSSARY	123
B. EMERGENCIES - TELEPHONE NUMBERS FOR AGENCIES	132
C. GENERAL CONTACT INFORMATION FOR AGENCIES	134

## **“UNIFIED CARRIER REGISTRATION ACT”**

The “*Unified Carrier Registration Act*,” (UCRA), which became effective in the latter part of 2007, replaced the Single-State-Registration Program. Under the UCRA, all motor carriers, brokers, freight forwarders, and persons leasing vehicles over 10,000 pounds were required to pay a registration fee for power units, trailers, and semi-trailers, etc., that operated in “interstate commerce.” **In 2010, trailers, and semi-trailers were removed from the fee structure and fees are only assessed for power units (trucks, truck tractors, and buses) over 10,000 pounds that operate interstate.**

Maryland does not participate in the UCRA, but Maryland motor carriers, brokers, freight forwarders and individuals leasing trucks, truck tractors and buses over 10,000 pounds which are used in “interstate commerce,” (that travel out of state) will be required to register under the UCRA. For additional information, visit the following website:

<http://www.ucr.in.gov>

If you have further questions regarding the UCRA, call the Maryland State Highway Administration, Motor Carrier Division toll-free 1-800-543-4564 (within Maryland only) or 410-582-5734.

## **COMPLIANCE, SAFETY, ACCOUNTABILITY PROGRAM (CSA)**

The CSA is a Federal Motor Carrier Safety Administration (FMCSA) program designed to improve the agency’s effectiveness in monitoring motor carrier and driver operations and enforcing the “*Federal Motor Carrier Safety Regulations*” (FMCSR). CSA is designed to “hold carriers and drivers accountable for their safety performance, demanding and enforcing safe on-road performance.” (FMCSA CSA 2010 information brochure).

A crucial component of CSA is the Safety Management System. The SMS is an automated system that includes motor carrier road safety performance data. FMCSA will use the "SMS result and serious violations contained in the Behavioral Analysis and Safety Improvement Categories (BASICs) to prioritize its enforcement resources." (FMCSA website) Carriers are encouraged to check their SMS online at the FMCSA website listed below.

Additionally, FMCSA's Pre-Employment Screening Program (PSP) "is designed to assist the motor carrier industry in assessing individual operators' crash and serious safety violation history as a pre-employment condition." (FMCSA website) Furthermore, under the PSP, individual drivers will also be allowed to obtain their driving records for review.

For additional information on the CSA, SMS, and PSP, visit the FMCSA website at:

<http://CSA2010.FMCSA.DOT.GOV>

## **CHANGES IN MARYLAND VEHICLE LAW - WHAT'S NEW**

During the 2010, and 2011 Maryland General Assembly the following changes took place:

### **Required Levels of Vehicle Insurance**

1. \*"Subject to §25-111 of the Transportation Article, a person who registers a tow truck in Maryland, or operates a tow truck in the State is required to obtain at least \$100,000 per person, \$300,000 per occurrence bodily injury liability, and \$100,00 per occurrence property damage liability."  
*(Maryland Vehicle Law, Title 13, §920)*
2. \*For vehicles subject to the "Federal Motor Carrier Safety Regulations" (FMCSR), and contained in the "Maryland Transportation Article, Title 25, §111", the security requirements contained in Title 49, Code of Federal Regulations (CFR), FMCSR, Part 387, apply.

3. \*Rules and regulations will be adopted specifying levels of Insurance for the following vehicles:
  - For-hire engaged in interstate commerce that:
    - (a) Exceed a gross vehicle weight rating of 10,000 pounds and are designed to carry property; or
    - (b) Are designed to transport passengers including the driver; and
    - (c) Those required to be marked or placarded for the transportation of Hazardous Materials or otherwise subject to the requirements of 49 CFR, Part 387 when transporting Hazardous Materials.

The 2010 law which took effect January 1, 2011 allows Maryland to enforce the provisions of the FMCSR regarding the insurance requirements for **interstate carriers**. The provisions of the 2011 law provides that the Motor Vehicle Administration along with the State Highway Administration will adopt regulations regarding the required levels of insurance for vehicles over 26,000 pounds GVW operated by **for-hire intrastate carriers of property** that are consistent with the FMCSR, Part 387. **This new section will become effective January 1, 2012.**

### **Increased Length for Saddle-mount and Full-mount combinations**

The maximum length for saddle-mount and full-mount combinations was increased from 75' to 97'.

This new law took effect October 1, 2010. Refer to "Maryland Vehicle Law, Title 24, §104.1."

### **Prohibited – Hand-held Telephone Usage**

"The driver of a motor vehicle that is in motion may not use the driver's hands to use a hand-held telephone other than to initiate or terminate a wireless telephone call or to turn on or turn off the handheld telephone."

"The driver may use a handheld telephone as a communication device utilizing push-to-talk technology." Also, a driver may use a cellular telephone in an emergency to dial 911.

This new law took effect October 1, 2010. Refer to "Maryland Vehicle Law, Title 21, §1124.1."

### **Move Over Law**

The driver of a vehicle approaching a stopped, standing or parked emergency vehicle from the rear on a highway that is using visual equipment is required to move over to an available lane if the movement is practical and not otherwise prohibited. If the driver is unable to make a lane change, the driver shall slow to a reasonable speed taking into account existing weather, road and vehicle or pedestrian traffic conditions.

This new law took effect October 1, 2010. Refer to "Maryland Vehicle Law, Title 21, §405."

### **EXCEPTIONAL HAULING PERMIT (EHP) FOR FARM PRODUCTS**

Effective June 1, 2011, the State Highway Administration has the authority to issue an Exceptional Hauling Permit (EHP) for vehicle combinations that are carrying Farm Products that:

- " Are loaded in fields or other off-highway locations
- Are the only load of the vehicle
- Has an axle configuration of not less than six axles and a front-to-rear centerline axle spacing of not less than 50 feet
- Comply with the following weight limits:
  1. A maximum of 20,000 pounds gross weight (GVW) on a single axle.
  2. For any consecutive axle configuration of two or more axles on individual vehicles in the combination, the maximum GVW, as specified in Title 24, §109 of the "Maryland Vehicle Law."
  3. A maximum of 87,000 pounds GVW."
- Twice each year submit to and pass a North American Standard Driver/Vehicle Level I inspection

The fee for an EHP is \$250 for the initial permit and a \$250 fee for annual renewals. The fee for a 30-day permit is \$30.

**An EHP is not valid for use on any Interstate Highway in the State, and it does not authorize a driver or company to violate any provision of the permit, or cross any restricted highway or bridges.**

For additional information regarding the provisions of this new law, call the State Highway Administration Motor Carrier Division, Hauling Permits Unit at 410-582-5734, or toll-free 1-800-846-6435 (within Maryland only)

## CHAPTER I

### INTRODUCTION

#### GENERAL RULES AND REGULATIONS

The "*Maryland Motor Carrier Handbook*," provides a summary of the federal and state laws governing commercial motor vehicle (CMV) operations in Maryland. **The material is provided only as a guide to assist you in understanding the law, and it should not be quoted as the law as it does not replace either Federal law or Maryland State law.** If you are interested in viewing the various laws and regulations and have access to a computer, visit the Motor Carrier Division's Commercial Vehicle Operations webpage at:

<http://www.roads.maryland.gov/CVO>

At the site, look for "Regulations," and you can either click on the federal regulations which will take you to the Federal Motor Carrier Safety Administration webpage, or click on Maryland law which will take you to a site where you can view sections of the "*Maryland Vehicle Law*."

The "*Federal Motor Carrier Safety Regulations*" (*FMCSR*), deal specifically with the federal CMV safety regulations pertaining to the movement of interstate commerce. Maryland has adopted most of the *FMCSR*, including those sections pertaining to the movement and control of Hazardous Materials (Haz-Mat), Commercial Driver's Licenses (CDL's), driver's qualifications, Hours-of-Service (HOS) and other sections not specifically mentioned here. Additional information on the regulations adopted by Maryland can be found later in this book. (Refer to Chapter XX) The *FMCSR* can be viewed online at the FMCSA website:

<http://www.fmcsa.dot.gov>

At the site, click on "Rules and Regulations." When the next page appears you will see the various "Parts," e.g., 40, 382, 383, etc. Parts that were adopted by Maryland include Part 40, 382, 383, 390 through 393 and 395 through 399.

If you wish to obtain copies of the FMCSR, you can find them at truck stops across the country, or you can contact one of several publishers who produce copies of them.

The Maryland Motor Carrier Portal is your one-stop shop on the Internet for motor carrier, CMV registration, and CDL information. The Portal provides links to enforcement and regulatory agencies involved in motor carrier processes in Maryland. It provides you with other information concerning the requirements for operation in the State. You can access the Portal at the following address:

<http://www.mdot.maryland.gov/MMCP/Index.html>

Additional information can be obtained from the Maryland Motor Vehicle Administration (MVA). MVA produces the "Maryland Driver's Handbook," "Maryland Commercial Driver's License Manual," and the "International Registration Plan Instructions for Apportionment." These publications are available from the MVA free of charge. The Maryland Department of the Environment's (MDE) "Hazardous Materials, Emergency Response Procedures Manual" is also available free of charge. Refer to Appendix C for the contact information for both agencies.

Maryland publishes an official highway/road map free of charge for use by the motor carrier industry which provides an overview of Maryland's extensive highway system. The new 2011 - 2012 edition of the "Maryland Trucker's Map," is available at Maryland's Truck Weigh and Inspection Stations, Official Welcome Centers and other locations. The map provides specific information on approved truck routes, access provisions for vehicle combinations, rest stops, truck stops, and other helpful information.

## A. TRUCK IDLING

*"The Maryland Transportation Article," Title 22, §402(c)(3), states, "A motor vehicle may not be allowed to operate for more than 5 consecutive minutes when the vehicle is not in motion except as follows:*

1. When a vehicle is forced to remain motionless because of traffic conditions or mechanical difficulties over which the operator has no control;
2. When it is necessary to operate heating and cooling or auxiliary equipment installed on the vehicle;
3. To bring the vehicle to the manufacturer's recommended operating temperature; or
4. When it is necessary to accomplish the intended use of the vehicle."

Unnecessary idling wastes fuel and causes more air pollution. There are times when vehicle idling is not necessary so please do your part to assist Maryland in reducing vehicle emissions and the release of harmful air-pollutants.

## B. A QUICK REFERENCE GUIDE

I NEED INFORMATION ON	WHO CAN I CONTACT
<p><b>Vehicle titles, registration/license plates for trucks, truck tractors, buses, and trailers, obtaining International Registration Plan (IRP) credentials, etc.</b></p>	<p>Maryland Motor Vehicle Administration (MVA)</p> <p>Contact information: 1-410-787-2971</p> <p>Calls within Maryland: 1-800-950-1682 (toll-free)</p>
<p><b>Driver's license, or commercial driver's license (CDL)</b></p>	<p>MVA</p> <p>Contact information: 1-301-729-4550</p> <p>Calls within Maryland: 1-800-950-1682 (toll-free)</p>
<p><b>USDOT Number – for Interstate travel</b></p>	<p>Federal Motor Carrier Safety Administration (FMCSA)</p> <p>Toll-free: 1-800-832-5660</p> <p>You can apply online at: <a href="http://www.fmcsa.dot.gov">www.fmcsa.dot.gov</a></p>
<p><b>USDOT Number – For Intrastate (staying within Maryland and not going Interstate) travel</b></p>	<p>Maryland State Highway Administration, Motor Carrier Division (MCD)</p> <p>Contact information: 1-410-582-5734</p> <p>Calls within Maryland: 1-800-543-4564 (toll-free)</p> <p>You can download the application form at: <a href="http://www.roads.maryland.gov">www.roads.maryland.gov</a></p>

I NEED INFORMATION ON	WHO CAN I CONTACT
<b>Fuel Tax decals/International Fuel Tax Agreement (IFTA), or Alcoholic Beverage Transportation Permits</b>	Comptroller of Maryland – Motor-fuel, Alcohol and Tobacco Tax Unit  Contact information: 1-410-260-7980  Calls within Maryland: 1-888-638-2937 (toll-free)
<b>Operating a taxi service or bus service, or conducting business of transporting passengers for-hire</b>	Maryland Public Service Commission  Contact information: 1-410-767-8128
<b>Access into and out of the Port of Baltimore</b>	Maryland Port Administration  Contact information: 1-800-638-7519 (toll-free)
<b>Hazardous Waste Permits</b>	Maryland Department of the Environment  Hazardous Materials Transportation contact information : 1-410-537-3975  Calls within Maryland: 1-800-633-6101 (toll-free)
<b>Oversize/Overweight Hauling Permits</b>	Maryland State Highway Administration, MCD  Contact information: 1-410-582-5727  Calls within Maryland only: 1-800-846-6435 (toll-free)

## C. USEFUL WEB PAGE ADDRESSES FOR AGENCIES

1. Maryland State Highway Administration (SHA)  
<http://www.roads.maryland.gov>
2. SHA Motor Carrier Division - Commercial Vehicle Operations  
<http://www.roads.maryland.gov/cvo>
3. Maryland State Police (MSP)  
<http://www.mdsp.org>
4. Maryland Transportation Authority (MDTA)  
<http://www.mdtta.maryland.gov>
5. Maryland Motor Vehicle Administration (MVA)  
<http://mva.maryland.gov>
6. Maryland Port Administration (MPA)  
<http://mpa.maryland.gov>
7. Maryland Department of Transportation (MDOT)  
<http://mdot.maryland.gov>
8. Maryland Comptroller  
<http://www.comp.state.md.us>
9. Maryland Public Service Commission (PSC)  
<http://www.webapp.psc.state.md.us>
10. Federal Motor Carrier Safety Administration (FMCSA)  
<http://www.fmcsa.dot.gov>
11. Maryland Department of the Environment (MDE)  
<http://www.mde.state.md.us>
12. Live Traffic Camera's (CHART)  
<http://www.chart.state.md.us/TravInfo/trafficCams.asp>
13. Maryland Motor Truck Association, Inc.  
<http://www.mmtanet.com>

## **D. HOMELAND SECURITY - PROTECTING AMERICA AND MARYLAND**

Since September 11, 2001, a great deal of effort has gone into reducing the threat of terrorism. Everyone shares a part in reducing this risk and we ask you to be observant while driving. If you observe something that appears to be suspicious activity near a bridge, overpass, or structure, please report it immediately to the police. Some examples of suspicious activity include, but are not limited to the following:

- Photographing/ videotaping a tunnel, bridge or other structure for no apparent reason, or
- Vehicle parked on the shoulder under a bridge, structure, or other location watching traffic, or
- Using video equipment to record activity near a bridge, structure, or other state, or local agency, or
- Stopping on bridges, structures, or other property to record video of piers, support beams, lighting, or security cameras, etc.

**If you have a cellular telephone available, please pull to the side of the road if it is practical to do so and dial #77. This will place you in contact with a Maryland State Police Barrack nearest you.** If it is unsafe to pull to the side of the road, when you are able to do so, please report this activity to the police. In some locations, your call may go to the nearest police agency. For example if you are driving on a route under the jurisdiction of the Maryland Transportation Authority – e.g. I-895, or I-695 (Francis Scott Key Bridge), your call may be directed to them. Regardless of where you may be in Maryland, your call will be answered by the police.

## E. FREQUENTLY ASKED QUESTIONS

On a daily basis, questions regarding commercial motor vehicle (CMV) movement are fielded by the Maryland agencies that are tasked with regulating them. For your convenience we have placed a list of the most frequently asked questions in this section for review to help you understand the regulations and requirements.

### 1. What is a commercial motor vehicle (CMV)?

A. There are two federal definitions for a CMV which determine how many of the "*Federal Motor Carrier Safety Regulations*" (FMCSR), will apply to you and your vehicle. The following vehicles/combinations used in interstate business or commerce are subject to all of the FMCSR found in Parts 390 through 399, **PLUS** drug testing requirements in Part 382, and Commercial Driver's License (CDL) requirements in Part 383:

1. Has a gross vehicle weight rating (GVWR) of 26,001 pounds or more;
2. Operating in combination and towing another vehicle where the gross combination weight rating (GCWR) is 26,001 pounds or more, and the GVWR of the towed vehicle exceeds 10,000 pounds;
3. Is designed or used to transport more than 15 passengers, including the driver;
4. Transporting a placardable amount of Hazardous Materials (Haz-Mat).

Smaller CMV's and combinations subject to Parts 390 through 393 and 395 through 399 are defined as:

1. Vehicles or vehicle combinations with a GVWR, or GCWR, or gross vehicle weight (GVW), or gross combination weight (GCW) of 10,001 pounds or more whichever is greater (i.e. a pickup truck pulling a trailer); or
2. A vehicle used to transport more than 8 passengers; or
3. A vehicle transporting placardable amounts of Haz-Mat.

**Drug testing and CDL regulations apply to all vehicles transporting a placardable amount of Haz-Mat and the driver must possess a CDL with a Haz-Mat endorsement.**

For additional information, please call the State Highway Administration's Motor Carrier Division number listed in Appendix C.

**2. Who is a motor carrier?**

A. A motor carrier can be someone who is either for hire or conducts business as a private motor carrier. A motor carrier includes motor carrier agents, officers and representatives, employees responsible for hiring, supervising, training, assigning, or dispatching of drivers and employees that perform duties dealing with the installation, inspection, and maintenance of CMV equipment and/or accessories.

**3. When dealing with "Commerce" what is the difference between "Interstate" and "Intrastate?"**

A. Both federal and state law can apply depending on what type of operation you run. Interstate transport is moving property from one state to or through another (Washington, D.C. is considered a state). Property that has its origin or destination outside of the state and is being picked up or delivered locally may be considered interstate cargo. The most common examples of this would be pier freight, air freight, U.S. Mail, and some distribution warehouse freight. Shipments transported entirely within the state, with no origin or destination outside of the state's borders is considered intrastate.

For additional information, please call the SHA Motor Carrier Division or the Maryland State Police Commercial Vehicle Enforcement Division (MSP/CVED) numbers listed in Appendix C.

**4. I am thinking about buying a truck. What do I need?**

A. We recommend you review the Handbook to determine what may apply to your operation.

**5. If I'm driving a CMV and get low on the available number of driving hours or am tired and need to stop and rest, are there places in Maryland where I can obtain rest?**

A. Maryland has many locations you may use to park to obtain rest. Refer to Chapter III for additional information.

**6. How much weight can I register my truck for?**

A. There are several things you need to know. First, what is the manufacturer's gross vehicle weight rating (GVWR) for your vehicle? In many cases, this rating can be found on the edge of the driver's door or the door frame. This is the best place to check for a label or sticker which has been applied by the manufacturer indicating what the GVWR is for the vehicle.

Next, if you are going to pull a trailer or other vehicle behind the truck, you need to be concerned with the manufacturer's gross combination weight rating (GCWR) for your truck. This likewise can be located on the edge of the driver's door or the frame pillar. If the GVWR and GCWR do not appear on the door plate, it is suggested you contact the dealer where you purchased your vehicle or vehicle manufacturer. Registering your vehicle for a weight over the GVWR or GCWR is not recommended. If you have additional questions, please call either the SHA Motor Carrier Division or the MSP/CVED numbers listed in Appendix C.

**7. What does the term IRP mean?**

A. The term IRP stands for the International Registration Plan. If you wish to travel in other states, the District of Columbia, or Canadian provinces, you may be required to obtain apportioned registration (in other words IRP authority to operate in those states/provinces) under certain circumstances. The IRP is based on the number of miles you anticipate traveling in that jurisdiction, the weight of your vehicle and/or combination, and the total number of axles. For more details, refer to Chapter V in the Handbook.

**8. I only go through your state twice a year. Do I still need to obtain IRP registration?**

A. If your vehicle or combination is required to be registered under the IRP, then yes, you are required to have it prior to entering and traveling in Maryland. Under the circumstances you will be required to obtain a temporary IRP Trip Permit from MVA which is valid for a period of 72 hours.

**9. What is the UCRA?**

A. The "Unified Carrier Registration Act," (UCRA) requires motor carriers operating trucks, truck-tractors, or buses over 10,000 pounds in interstate commerce to register. Brokers of freight, and freight forwarders as well as persons leasing motor vehicles over 10,000 pounds are required to register under the UCRA.

Maryland does not participate in the UCRA. If you have questions regarding this matter, call the SHA Motor Carrier Division number listed in Appendix C.

**10. What does the term IFTA stand for?**

A. The term IFTA stands for the International Fuel Tax Agreement, and it pertains to fuel tax permits. You may be required to obtain IFTA decals for your vehicle under certain circumstances based on:

- The number of axles on your vehicle
- The gross vehicle weight, and
- Where you travel (e.g., other states, and Canadian provinces)

To obtain more information, refer to Chapter VI in the Handbook. If you have additional questions, please call the Motor-fuel, Alcohol and Tobacco Tax Unit, Comptroller of Maryland at:

**410-260-7980**  
**OR**  
**1-888-638-2937 (Toll-free within Maryland only)**

## **11. I own a CMV. Do I need any markings on it?**

A. Depending on what you haul and where you travel will determine what type of markings you are required to display on your vehicle. For more information, please refer to Chapter VII in the Handbook. If you have additional questions, please call the SHA Motor Carrier Division number listed in Appendix C.

## **12. Do I need any type of permit to travel in Maryland?**

A. If you are a interstate carrier, you will need to obtain a USDOT Number for your vehicle. A USDOT Number can be obtained free of charge by contacting the Federal Motor Carrier Safety Administration (FMCSA). You can also apply on-line at their website: <http://www.fmcsa.dot.gov>

If you are a for-hire carrier operating interstate, in addition to displaying a USDOT Number, you will be required to obtain an MC Number from FMCSA. To apply online, go to the following website: <http://www.fmcsa.dot.gov>

If you operate only intrastate (in Maryland only) and do not haul interstate cargo, you will need to obtain a Maryland USDOT Number which can be obtained free of charge. For additional information, refer to Chapter VII in the Handbook.

If you still have questions, please call the SHA Motor Carrier Division number listed in Appendix C.

## **13. When do I need a Commercial Driver's License (CDL)?**

A. You are required to possess a CDL when you are driving a CMV that fits the criteria specified in "[The Maryland Vehicle Law.](#)" Refer to Chapter VIII in the Handbook for an explanation of what a CMV is, and the class of driver's license or CDL that will be required before you drive a particular CMV. To be allowed to operate some types of vehicle combinations, or carry certain cargo, you may be required to obtain an endorsement on your CDL.

**14. What is a DOT physical?**

A. A DOT physical is performed by a physician who certifies that you are medically qualified to drive a CMV that is 10,001 pounds or greater in interstate or intrastate operation. If you operate a CMV or CMV combination that is 10,001 pounds or greater either intrastate or interstate, you must have the original or a copy of this certification in your possession. To be valid, a DOT physical must be performed at least every two years from the date of your last DOT physical and be current. You can download the medical form which you take to your doctor at the MVA website:

<http://www.mva.maryland.gov/Resources/DL-171.pdf>

If you have questions concerning this issue, please call the SHA Motor Carrier Division numbers listed in Appendix C.

**15. I drive a vehicle and haul Hazardous Materials (Haz-Mat). Do I need permits to move this type of freight?**

A. This depends on what type of Haz-Mat cargo you are hauling. In some instances, you are required to possess a permit from either the Federal Motor Carrier Safety Administration (FMCSA), or the Maryland Department of the Environment (MDE) or both.

For FMCSA call: 410-962-2889

For MDE call: 410-537-3400

**16. I haul Hazardous Materials. Are there any routes where my travel is restricted in Maryland?**

A. **Yes. Vehicles carrying Hazardous Materials (Haz-Mat) are prohibited from traveling through either the I-895 Baltimore Harbor Tunnel, or the I-95 Fort McHenry Tunnel.** For additional information call the Maryland Transportation Authority Police number listed in Appendix C.

**17. I have a motor home that has a propane tank mounted outside the vehicle. Is my travel restricted in Maryland?**

A. **Yes.** Motor homes and vehicles towing trailers (camping or travel) that are carrying propane tanks are prohibited from traveling through either the I-895 Baltimore Harbor Tunnel, or the I-95 Fort McHenry Tunnel. For additional information call the Maryland Transportation Authority Police number listed in Appendix C.

**18. I have a truck and/or truck tractor trailer and will be hauling Bull dozers and other large vehicles that are wider than my vehicle. Do I need to obtain any type of permit to move them? If so, where do I obtain an Oversize/Overweight Hauling Permit?**

A. To obtain information pertaining to the legal size and weight of your vehicle, please call the State Highway Administration's Hauling Permits Unit number listed in Appendix C.

**19. What is the legal maximum height, width and length for a vehicle (or vehicles) in Maryland?**

A. For information on vehicle height, width and length, refer to Chapter XII in the Handbook.

**20. I have a truck and will be pulling a trailer. How long can the combination of vehicles be?**

A. A combination of vehicles consisting of a power unit that is a cargo carrying vehicle is allowed a maximum length of 62 feet.

**21. How many hours may I drive a truck and/or bus? Am I required to keep any record of my driving hours?**

A. Different situations apply here. Consult Chapter XX in this Handbook for more details. To obtain more information concerning the Hours of Service, please visit the Federal Motor Carrier Safety Administration (FMCSA) website at:

<http://www.fmcsa.dot.gov>

Or you can call the SHA Motor Carrier Division number listed in Appendix C.

**22. I am a farmer. Am I exempt from any of the laws dealing with commercial motor vehicles?**

A. You may be exempt from certain portions of Maryland law and/or Federal law. To obtain more information, please call the SHA Motor Carrier Division number listed in Appendix C.

**23. What does the term gross vehicle weight rating (GVWR) mean, and how is it applied?**

A. The term "GVWR" is a weight rating that is applied to a specific vehicle by the manufacturer indicating the maximum safe fully-loaded operating weight. This includes the weight of the vehicle and any load carried.

**24. What does the term gross vehicle weight (GVW) mean, and how is it applied?**

A. The term "GVW," as defined in "*The Maryland Vehicle Law*," means the weight of the vehicle and any load. The GVW is determined several ways. For more information, refer to Chapter XIV which provides information on the Bridge Formula and GVW.

**25. I have a truck and pull a trailer behind it. The total weight of both vehicles is 10,500 pounds. Do I have to pull into the Weigh Stations in Maryland?**

A. **Yes.** Traffic control signs are posted prior to all Weigh Stations in Maryland indicating that all vehicles with a gross vehicle weight rating or gross combination weight rating over 10,000 pounds must pull into them. Therefore, if the total weight rating of both vehicles is over 10,000 pounds, you are required by law to pull into the weigh station.

**26. I have heard about a Preventive Maintenance (PM) Program. What is it?**

A. The PM Program requires the owners of certain Maryland registered vehicles that are over 10,000 pounds gross vehicle weight rating, gross vehicle weight, or operating weight to perform vehicle inspections on that particular vehicle at specific intervals. These intervals are based on mileage and/or time frames. Refer to Chapter XIX contained in the Handbook for more details.

**27. What is the Diesel Vehicle Emissions Control Program? Does it apply to me?**

A. The Diesel Vehicle Emissions Control Program is designed to ensure diesel powered vehicles over a specific weight are not emitting harmful emissions. For additional information, please call the MSP/CVED number listed in Appendix C.

**28. What is the Noise Abatement Program? Does it apply to me?**

A. The Noise Abatement Program is designed to reduce noise pollution regarding large trucks and buses. For additional information, please call the MSP/CVED number listed in Appendix C.

**29. I'm towing a semi-trailer exceeding 48 feet in length up to, but not exceeding 53 feet in length. Is my travel restricted in Maryland?**

A. YES. Your travel is restricted to certain routes. Refer to Chapter II for additional information.

**30. I am thinking of starting a tow truck business. Do I need a business license from the State of Maryland?**

A. You do not need a business license from the State of Maryland, but are required to register with the Comptroller of Maryland for tax purposes. For additional information visit:

<http://www.comp.state.md.us>

Additionally, you may be required to obtain a business license from the county, city or town where your business is located in addition to registering with the Comptroller of Maryland. To determine if you need a business license, check with the Clerk of the Circuit Court in your county. If the county does not require a business license, you still need to check with your town or city office. You can obtain contact information for the Clerk of the Court for the various counties in Maryland by visiting the following website:

<http://www.mdcourts.gov/circuit/directory.html>

## CHAPTER II

### MARYLAND TRUCK ROUTE SYSTEM

The following vehicle combinations, regardless of the allowable width, are required to operate on the Maryland National Network System of Highways (Refer to the next page for a listing of the System):

- Truck tractor pulling a semi-trailer that exceeds 48 feet in length up to a length not to exceed 53 feet\*
- Truck or truck tractor-semi-trailer combination designed for and engaged exclusively in the transportation of automobiles or boats not exceeding 65 feet in length\*
- Stinger-steer automobile/boat transporters\*
- Saddle mount, or full-mount combinations\*
- Maxi-cube combinations\*
- Truck tractor-semi-trailer-trailer combinations (doubles)\*

**\*Travel restrictions apply for these vehicle combinations.** Other roads may be used by these combinations only for access to the system provided that they are the shortest practical access route between a highway designated, and a truck terminal, point of origin or destination of cargo. Additionally, truck tractors pulling a semi-trailer exceeding 48' in length up to a length not to exceed 53' are restricted to a distance ½ mile off the system to obtain food, fuel, rest, or repairs. The other combinations listed are restricted to a distance of 1 mile off the system to obtain food, fuel, rest, or repairs.

The segment of US 40 from Maryland Route 279 to Maryland Route 152 is a designated route which may be used by the aforementioned vehicles for local deliveries and they may not exceed those limitations set forth in "*The Maryland Vehicle Law.*"

If you have questions concerning access provisions and routing restrictions call the SHA/MCD at 410-582-5734 or toll-free (within Maryland only) at 1-800-543-4564.

The following Maryland National Network System of Highways is a system designated by the Maryland Secretary of Transportation in conjunction with the Federal Highway Administration (FHWA). The System includes all Interstate Highways (I-68, I-70, I-81, I-83, I-95, I-97, I-195, I-270, I-370, I-395, I-495, I-695, I-795, and I-895\*) and the below listed highways: (See operational requirements on the previous page)

ROUTE	FROM	TO
US 13	Virginia State Line	Delaware State Line
US 15	US 340, Frederick	MD 26, north of Frederick
US 40	US 340, Frederick	I-70, Frederick
US 50	MD 201, Kenilworth Avenue	US 13 Salisbury Bypass
US 301	Virginia State Line	Delaware State Line
US 340	MD 67 at Weverton	US 40 in Frederick
MD 3	US 50/301 at Bowie	I-97
MD 4	I-95	US 301, Upper Marlboro
MD 10	MD 100, Glen Burnie	I-695 Baltimore Beltway
MD 100	MD 607, Jacobsville	I-97
MD 201	US 50, Cheverly	DC Line
MD 295	I-695 Baltimore Beltway	I-95 north of the Baltimore City Line
MD 695 (Baltimore Beltway, southeastern loop)	I-695 at Exit 1	North Point Boulevard (MD 151)
MD 702	I-695 east of Baltimore	Old Eastern Avenue

\*See exceptions for I-895 on the next page

**NOTE – VEHICLES CARRYING HAZARDOUS MATERIALS ARE NOT ALLOWED TO TRAVEL ON I-895 (BALTIMORE HARBOR TUNNEL) OR I-95 (FT. MCHENRY TUNNEL).**

The Maryland Transportation Authority maintains I-895, the Baltimore Harbor Tunnel (BHT).

**IF YOU ARE DRIVING ANY OF THE FOLLOWING VEHICLE COMBINATIONS YOU ARE NOT ALLOWED TO DRIVE THROUGH THE BALTIMORE HARBOR TUNNEL:**

- Double vehicle combinations which consists of a truck tractor-semi-trailer-trailer
- **Any vehicle or combination which is over 96 inches (8 feet) in width**
- Semi-trailers exceeding 48' in length up to a length not exceeding 53'. These vehicles are 102 inches (8 feet 6 inches) in width

**VIOLATORS WILL BE TICKETED AND THE MINIMUM FINE IS \$520.00.**

Alternate routing is available via I-695 and the Francis Scott Key Bridge or I-95 Fort McHenry Tunnel. For specific information, contact the Maryland Transportation Authority at:

Maryland Transportation Authority Police  
Tunnel Command  
2301 South Clinton Street  
Baltimore, Maryland 21224

**Telephone # 410-537-1230**

**or**

**1-888-754-0185**

## CHAPTER III

### TRUCK PARKING

#### A. TRUCK WEIGH AND INSPECTION STATIONS (TWIS)

Truck parking is permitted at Maryland Truck Weigh and Inspection Stations (TWIS) when these facilities are closed. **Inspections will not be performed on trucks already parked at weigh facilities during these times.** The following TWIS allow truck parking when they are closed:

1. Eastbound I-68, Finzel TWIS  
Number of spaces: 12
2. Westbound I-70, West Friendship TWIS  
Number of spaces: 18
3. Eastbound I-70, New Market TWIS  
Number of spaces: 15
4. Northbound I-95, Perryville TWIS  
Number of spaces: 59
5. Southbound I-95, Perryville TWIS  
Number of spaces: 52
6. Northbound I-270, Hyattstown TWIS  
Number of spaces: 12
7. Southbound I-270, Hyattstown TWIS  
Number of spaces: 12
8. Southbound US 301 @ MD 299,  
Cecilton TWIS  
Number of spaces: 25
9. Northbound/Southbound US 1  
Conowingo TWIS  
Number of spaces: 7

Additional parking is available at the following Truck Weigh and Inspection pull-off sites when they are closed:

- US 50 @ Vienna (Wicomico County)  
Number of spaces: 12
- I-95/495 Park & Ride  
Number of spaces: 11

## B. MARYLAND WELCOME CENTERS

In 2009, the State Highway Administration modified service hours to primarily daytime hours at several areas for economic reasons. Only one, sparsely used rest area is permanently closed. Truck parking at some locations is limited to daytime parking only. Prior to traveling, check the following website for additional information:

<http://www.roads.maryland.gov/Index.aspx?PageId=250&d=44>

1. Eastbound I-68 at Youghiogheny  
Number of available spaces: 12
2. Eastbound I-70 between Exits 35 & 42  
Number of available spaces: 26
3. Westbound I-70 between Exits 42 & 35  
Number of available spaces: 23
4. US 15 south of the Pennsylvania State Line  
Number of available spaces: 15\*

**Note – The parking area for trucks is open only from 7 a.m. until 5 p.m. daily. At 5 p.m. the entrance ramp to the parking lot will be closed by locked gate. Trucks that are parked on the lot prior to 5p.m. will be allowed to stay.**

5. Southbound I-95 near Laurel between Exits 38 & 35  
Number of available spaces: 19
- Northbound I-95 near Laurel between Exits 35 & 38  
Number of available spaces: 21

- 6. I-95 near Aberdeen (Harford County)
  - Maryland House
  - Northbound number of spaces available: 30
  - Southbound number of spaces available: 20

- 7. I-95 near North East (Cecil County)
  - Chesapeake House
  - Northbound number of spaces available: 47
  - Southbound number of spaces available: 49

- 8. Northbound US 13 at Virginia State Line (Somerset County)
  - Number of spaces available: 10\*

**\*Note – This center is open only from 7 a.m. until 7 p.m. At 7 p.m. the entrance ramp to the parking lot will be closed by a locked gate. Trucks that are parked on the lot prior to 7 p.m. will be allowed to stay.**

- 9. US 301 near Centreville (Queen Anne’s County) Bay Country Welcome Center
  - Number of spaces available: 15

The following location is for truck parking only and is not a Welcome Center.

- Eastbound I-70 east of the New Market TWIS
  - Number of available spaces: 9\*

**\*Note – There are no services at this location.**

IT IS UNSAFE TO PARK OR STOP ON THE SHOULDERS OF HIGHWAYS. WE RECOMMEND YOU USE THE FACILITIES LISTED FOR PARKING.

**“A PERSON MAY NOT STOP, STAND, OR PARK A VEHICLE ON ANY ENTRANCE OR EXIT RAMP OF ANY HIGHWAY WITH TWO OR MORE LANES FOR TRAFFIC MOVING IN THE SAME DIRECTION.” (*The Maryland Vehicle Law, Title 21, §1003 (k)*)**

### C. PRIVATE TRUCK STOPS

Truck parking is available at private truck stops across Maryland. Should you have any questions regarding conditions on parking at a truck stop, please call the telephone numbers listed for those locations.

COUNTY	NAME/LOCATION	
Anne Arundel	New Transit Truck Stop Veteran's Highway, Exit #11 off I-97, Millersville, MD. Telephone # 410-987-1444 Number of parking spaces:	50
Baltimore City	Travel Centers of America Roadway In Maryland O'Donnell Street, Exit #57 off I-95, Baltimore, MD. Telephone # 410-633-4611 Number of parking spaces:	250
Cecil	Flying "J" Truck Stop Center Drive, Exit #100 off I-95, North East, MD. Telephone # 410-287-7110 Number of parking spaces:	156
	Flying "J" Truck Stop Bell Hill Road, Exit #109A off I-95, Elkton, MD. Telephone # 443-245-4229 Number of parking spaces	218
	Pilot Travel Center, Heather Lane, Exit #93 off I-95, Perryville, MD. Telephone # 410-642-2883 Number of parking spaces:	63

Cecil  
Travel Centers of America,  
Elkton Road, Exit #109 off I-95,  
Elkton, MD.  
Telephone # 410-398-7000  
Number of parking spaces: 160

Charles  
One Stop Travel Plaza  
US 301 @ MD 257,  
Newburg, MD.  
Telephone # 301-259-2662  
Number of parking spaces: 200

Garrett  
Keyser's Ridge Truck Stop,  
National Pike, Exit #14A off I-68,  
Accident, MD.  
Telephone # 301-746-8710  
Number of parking spaces: 30

Fuel City  
Exit #22 off I-68,  
Grantsville, MD.  
Telephone # 301-895-3233  
Number of parking spaces: 45

Pilot Travel Center # 408  
3000 Chestnut Ridge Road  
Exit 22 off I-68, north on US 219,  
Grantsville, MD.  
301-895-4536  
Number of parking spaces: 44

Howard  
Travel Centers of America  
Baltimore South, Assateague  
Drive, Exit #41 off I-95,  
Jessup, MD.  
Telephone # 410-799-3835  
Number of parking spaces: 400

Talbot	Easton Truck Stop US 50, Easton, MD. Telephone # 410-763-8090 Number of parking spaces:	7
Queen Anne's	Trailways Truck Stop US 301 @ MD 304, Centreville, MD. Telephone # 410-758-2444 Number of parking spaces:	100
Washington	AC & T Fuel Center Exit #5B off I-81, Hagerstown, MD. Telephone # 301-582-2702 Number of parking spaces:	140
	Hancock Truck Stop, MD 144, Exit #3 off I-70, Hancock, MD. Telephone # 301-678-7111 Number of parking spaces:	88
	Pilot Travel Center 150 Exit #24 off I-70, Hagerstown, MD. Telephone # 301-582-9004 Number of parking spaces:	83
	Pilot Travel Center Exit 5B off I-81 onto Halfway Blvd., then left onto Hopewell Road, Hagerstown, MD. Telephone # 301-582-6111 Number of parking spaces:	84

## CHAPTER IV

### REGISTERING YOUR VEHICLE

#### A. GETTING STARTED

The Maryland Motor Vehicle Administration (MVA) is the agency responsible for issuing titles and registrations for vehicles that are required to be registered in the State. Different conditions apply for obtaining titles for new or used vehicles. For the purpose of registration, MVA issues different classes of registration for various vehicles. For example, single unit light duty and heavy duty trucks are classified as Class "E" type vehicles, and trailers and semi-trailers are classified as Class "G" type vehicles.

Since different conditions apply, it is not possible to cover every aspect of what will be needed. The information provided in this Chapter is designed to assist you in determining what you will need.

If after reviewing this Chapter you have questions regarding obtaining a title or registering a vehicle, please call the MVA numbers listed in Appendix C.

## B. TITLES AND REGISTRATION

The process to title and register a new vehicle is fairly simple. Refer to the block below for additional information.

### “A certificate of title is not required for:

- A vehicle owned and used by the United States, unless it is registered in this State;
- A new vehicle owned by a manufacturer or dealer and held for sale;
- A vehicle used by a manufacturer only for testing;
- A vehicle owned by a non-resident of this State and not required to be registered in this State;
- A vehicle regularly engaged in the interstate transportation of people or property and for which a currently effective certificate of title has been issued by another state;
- A vehicle moved only by human or animal power;
- A bicycle;
- A vehicle in which interest has passed to a secured party on default of the owner;
- Farm equipment;
- Special mobile equipment;
- A trailer, other than camping trailer, rated by the manufacturer as having a gross vehicle weight of 2,500 pounds or less.” (*The Maryland Vehicle Law, Title 13, §102*)

I have	And need	What will I need to provide MVA?
A new vehicle	A title, and registration	<ol style="list-style-type: none"> <li>1. A certificate of origin (CO) from the manufacturer; and</li> <li>2. An application for a title using MVA Form VR-5; and</li> <li>3. Payment of an excise tax (6% of the market value for the vehicle); and</li> <li>4. If the vehicle is over 55,000 pounds, evidence that the federal Heavy Vehicle Use Tax (HVUT) has been paid; and</li> <li>5. An application for registration; and</li> <li>6. Payment of appropriate fees.</li> </ol>

I have bought a	And need	What will I need to provide MVA?
Used vehicle	A title, and registration	<ol style="list-style-type: none"> <li>1. A title from the former owner that has been signed over to you; and</li> <li>2. If the vehicle was registered or titled in another state, a notarized bill of sale signed by the seller will be required; and</li> <li>3. If the vehicle was not titled or registered a certificate of origin (CO) from the manufacturer; and</li> <li>4. An application for a new title on MVA Form VR-5; and</li> <li>5. An application for new registration; and</li> <li>6. A vehicle inspection certificate; and</li> <li>7. Payment of a 6% excise tax for the fair market value of the vehicle*; and</li> <li>8. If the vehicle is over 55,000 pounds, evidence that the HVUT has been paid; and</li> <li>9. Any other information MVA may need to verify the legal ownership of the vehicle; and</li> <li>10. Payment of appropriate fees.</li> </ol>

\*MVA may allow a tax credit if a similar tax was paid in another state and the vehicle is titled in Maryland within the first 60 days of established residency.

## C. FEDERAL HEAVY VEHICLE USE TAX (HVUT)

The Maryland Motor Vehicle Administration (MVA) requires the owners of vehicles with a gross vehicle weight (GVW) of 55,000 pounds or more to produce proof of payment of the HVUT before registration plates or renewal stickers can be issued. Proof of

payment is not required for newly acquired vehicles registered within 30 days. The IRS requires that you complete and file two forms, IRS Form 2290 – Heavy Highway Vehicle Use Tax Return and Schedule 1 (Form 2290 – Schedule of Heavy Highway Vehicles).

### HVUT Information

If you have questions regarding the HVUT, call the MVA at :

410-787-2971 or toll-free (within Maryland only) at 1-800-248-4160

The application for registration that you send or provide to MVA must include a photocopy of the HVUT Return (IRS Form 2290) and Schedule 1 (Form 2290). If you have not obtained a receipted Schedule 1 (Form 2290) from the IRS when applying for registration, you may present the three following documents:

- Photocopy of IRS Form 2290
- Photocopy of Schedule 1
- Photocopy of both sides of the canceled tax payment check

If you have any questions regarding IRS Form 2290, please call the IRS Form 2290 Call Site, Toll-free at 1-866-699-4096. The hours of operation of the site are Monday – Friday, 8 a.m. to 6 p.m., Eastern Time. You can also visit the IRS website at:

<http://www.irs.gov>

## **D. PREVENTIVE MAINTENANCE CERTIFICATION**

To be in compliance with the Maryland Preventive Maintenance (PM) Program, (***The Maryland Vehicle Law, Title 23, Subtitle 3***), the registrant of a vehicle with a registered, operating, or rated gross vehicle weight over 10,000 pounds must certify that they have personal knowledge of applicable federal and state motor carrier safety rules, regulations, and standards, and that they are participating in Maryland's PM Program. This certification must be made when:

- Purchasing new registration plates, and
- At the time of renewing registration plates

## **E. FEES**

### **1. PARTIAL YEAR REGISTRATION**

If the registration of a commercial motor vehicle is issued for a period of less than the full annual registration year, the fee will be one quarter of the annual registration fee multiplied by the number of quarters remaining in the registration year. The above calculation must include the quarter in which the registration takes effect.

### **2. REGISTERING SINGLE UNIT TRUCKS**

For each Class "E" single unit truck with two or more axles, the annual registration fees will be based on the maximum gross weight of the vehicle or combination of vehicles. The annual registration renewal cycle is staggered for Class "E" single unit trucks.

The schedule shown on the next page is used by MVA to calculate the fees for either the GVW, or gross combination weight (GCW) of a vehicle, whichever is applicable.

The fee structure chart below is for Class "E" trucks.

<b>GROSS WEIGHT CATEGORIES (IN POUNDS)</b>	<b>FEE (PER 1,000 LBS. OR FRACTION THEREOF)</b>
(MIN.) 10,000 - 18,000	\$ 9.00
18,001 - 26,000	\$ 11.75
26,001 - 40,000	\$ 12.75
40,001 - 60,000	\$ 14.75
(MAX.) 60,001 - 80,000	\$ 16.00

Please note that each truck with a manufacturer's rating of 1/2 ton or 3/4 ton is limited to a GVW of 7,000 pounds.

### 3. REGISTERING DUMP SERVICE VEHICLES (DSV)

Class "E" "dump service registration" fees are the greater of \$26.25, for each 1,000 pounds GVW, or \$1,050.00. The annual registration renewal cycle for "dump service registration" is staggered.

The maximum gross weight limitation for a DSV is as follows:

- Two axles = 40,000 pounds\*
- Three axles = 55,000 pounds (see (a) below), or 65,000 pounds (see (b) below)
- Four axles = 70,000 pounds

\*Although a two-axle DSV will be allowed a GVW of 40,000 pounds, that vehicle cannot exceed the weight rating for the tires (combined). If the vehicle weight exceeds the tire rating, it will be placed Out Of Service and the driver will be issued a citation.

(a) Three axle DSV registered after June 1, 1994, are allowed a maximum GVW limit of 55,000 pounds.

(b) Three axles DSV – SPECIAL CONDITIONS

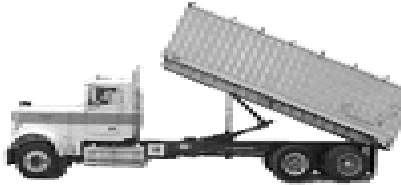

**3-axle**

Three axle DSV registered before June 1, 1994 may continue to operate at the 65,000 pound GVW limit specified in the law in effect on May 31, 1994, for a period of 20 years if:

- 1) For a new vehicle registered for the first time – the later of the vehicle’s model year or date of registration; or
- 2) For a used vehicle – the vehicle’s model year.

(c) FOUR (or more) AXLES DSV – SPECIAL CONDITIONS



**4-axle**

**NOTE – Maryland registered DSV’s with four axles (4<sup>th</sup> axle being a lift-axle) must comply with the Code of Maryland Regulations (COMAR) before being allowed a GVW of 70,000 pounds. Delaware registered DSV with four axles are only allowed a maximum GVW of 70,000 pounds in certain counties when in compliance with the Maryland/Delaware reciprocity agreement.**

**ALL OTHER NON-DSV AND OUT-OF-STATE MULTIPLE AXLE VEHICLES ARE REQUIRED TO COMPLY WITH THE BRIDGE FORMULA FOR GVW AND AXLE WEIGHTS.**

**For additional information, call either the SHA/MCD at 410-582-5734, or the MSP/CVED at 410-694-6100.**

Maryland registered four-axle DSV that are equipped with a lift-axle are required to comply with the following:

- 1) The lift axle installed on a vehicle shall have a manufacturer's, second stage manufacturer's, or authorized dealer's certification to carry the minimum axle load of 13,500 pounds (The certification must be presented when registering the vehicle); and
- 2) The lift axle shall be designed only to be fully engaged when in the down position; and
- 3) Air pressure adjustment controls may not be mounted inside the cab, but the switch capable of fully engaging or disengaging the lift axle may be mounted inside the cab; and
- 4) Existing vehicles retrofitted with a lift axle will comply with the same regulations and design requirements as a newly manufactured vehicle.

**Applying for dump service registration – What does MVA need?**

**Two and Three-axes:**

- **Dump Service Certification Form (Form VR-98)**
- **Side photograph of the vehicle**
- **Proof of payment of HVUT**
- **Payment of appropriate fees**

**Four or more axes:**

- **Dump Service Certification Form (VR-98)**
- **Manufacturer's, second-stage manufacturer's, or authorized dealer's certification that vehicle is in compliance with design requirements**
- **Proof of payment of HVUT**
- **Payment of appropriate fees**

Generally, a DSV is allowed to haul bulk materials for a distance of not more than 40 miles. If the vehicle is registered for 55,000 pounds GVW, or if it is a four-axle vehicle with a maximum GVW of 70,000 pounds (in compliance with all applicable regulations), it may operate statewide without distance limitations.

If the vehicle is a four axle DSV operated on Interstate 68 (I-68) in Allegany and/or Garrett counties to haul coal, logs, or pulpwood, then a maximum GVW weight of 70,000 pounds is permitted even if it is not in compliance with the regulations adopted by Maryland regarding vehicle configuration.

#### **4. REGISTERING TRUCK/TRAILER COMBINATIONS**

When a truck is operated in combination with a freight trailer or semi-trailer, the truck shall be registered for the GCW of the truck and the trailer or semi-trailer if the trailer is in excess of 20,000 pounds.

The fee for this combination is the same as shown for a single unit truck. When operating as a single unit, you are limited to the GVW as selected by you and indicated on your registration card.

When operating in combination, the weight of your vehicles may not exceed the registered weight, or applicable axle and/or gross vehicle/combination weights as determined by the Bridge Formula. For information on axle and Bridge Formula weights, refer to Chapter XIV in the Handbook.

## 5. REGISTERING TRACTOR/TRAILER COMBINATIONS

The annual registration fee is based on the maximum GCW of the truck tractor and trailer as follows:

GROSS WEIGHT CATEGORIES (IN POUNDS)	FEE (PER 1,000 POUNDS OR FRACTION THEREOF)
40,000 (Minimum) - 60,000	\$ 21.00
60,001 - 80,000 (Or more)	\$ 22.50

The annual registration renewal cycle for these vehicles is staggered.

## 6. REGISTERING FREIGHT TRAILERS

For a freight trailer or semi-trailer used in combination with a truck or truck tractor, the registration fee is \$38.25 (includes motor freight and farm trailers over 20,000 pounds). An eight-year registration is optional for owners of trailer and semi-trailer fleets of five or more.

## 7. REGISTERING NON-FREIGHT TRAILERS AND FARM VEHICLES

Maximum gross weight limits and fees for non-freight trailers and farm vehicles are available by calling the MVA. A non-freight trailer is a vehicle designed for towing by:

- A passenger vehicle
- Multi-purpose vehicle
- Class "E" truck

If towed by a Class "E" truck, the trailer shall have a GVW of 20,000 pounds or less. If towed by a Class "A" passenger vehicle or Class "M" multi-purpose vehicle, the trailer shall have a GVW of 10,000 pounds or less and be:

- A boat trailer
- Camping trailer
- House trailer
- Utility trailer

Single unit trucks may be registered as farm trucks, and truck tractors may be registered as farm truck tractors providing the applicant is a farmer and specifies the vehicle's proposed use. A farm truck or farm truck tractor may not be used for-hire, except to haul farm products for another farmer.

"For a non-freight trailer with a maximum gross weight limit (in pounds) of 10,001 to 20,000 that is titled on or after October 1, 2005:

- (i) The fee is \$124.00; and
- (ii) The vehicle shall be registered in one of the following weight ranges:

- 10,001 to 11,000
- 11,001 to 12,000
- 12,001 to 13,000
- 13,001 to 14,000
- 14,001 to 15,000
- 15,001 to 16,000
- 16,001 to 17,000
- 17,001 to 18,000
- 18,001 to 19,000
- 19,001 to 20,000"

("The Maryland Vehicle Law,  
Title 13, §927")

## CHAPTER V

### INTERNATIONAL REGISTRATION PLAN (IRP)

#### APPORTIONED REGISTRATION

The International Registration Plan (IRP) is a plan for apportioned registration, based on mileage for commercial vehicles engaged in interstate operations.

#### **Who must obtain apportioned registration?**

If your vehicle, or fleet travels in Maryland **and** any other IRP jurisdiction and it is used for:

1. Transportation of persons for-hire, or is designed, used, or maintained primarily for the transportation of property; and
2. Has a power unit having two axles and a gross vehicle weight or registered gross weight in excess of 26,000 pounds; or
3. Has a power unit having three or more axles regardless of weight; or
4. Is used in combination when the weight of such combination exceeds 26,000 pounds GVW.

Under the IRP, the interstate carrier is required to file an application with the jurisdiction in which the carrier is based. A carrier must meet the requirements for an established place of business or be able to show residency. (Refer to Appendix A for the definition for an established place of business and residency requirements).

The "Base Jurisdiction" (Refer to Appendix A for definition of term) issues an "apportioned" license plate and cab card. The license plate and cab card allows both interstate and intrastate vehicle movement/travel. The IRP cab card will list the jurisdictions where the carrier has paid apportioned registration fees and is allowed to operate.

A carrier may be required, depending on circumstances, to participate in the International Fuel Tax Agreement (IFTA) and may be required to comply with other regulatory programs in the jurisdiction where traveling.

#### Member IRP Jurisdictions

- 48 continental US States
- District of Columbia
- The following Canadian provinces:
  - Alberta
  - British Columbia
  - Manitoba
  - New Brunswick
  - Newfoundland/  
Labrador
  - Nova Scotia
  - Ontario
  - Prince Edward Island
  - Quebec
  - Saskatchewan

#### Exemptions from IRP

- **Government vehicles**
- **Buses used in the transportation of chartered parties**
- **Recreational vehicles**
- **Vehicles displaying a restricted plate**

### IRP VS. FUEL TAXES/OPERATING AUTHORITY/OVERSIZE OVERWEIGHT VEHICLES

#### Apportioned registration DOES NOT:

- Waive or exempt a carrier from obtaining any other travel authority as required by the respective jurisdiction, or
- Waive or exempt the payment of motor fuel taxes or registration in the IFTA as required by each participating state, or
- Permit anyone to exceed the maximum height, width, length, or weight limitations.

## **INITIAL APPLICATIONS**

For questions, call the MVA numbers listed in Appendix C.

Please do not send fees for apportioned registration with your application. MVA will send a billing notice for payment due. This will help ensure correct payment, avoid over or under payments and speed the mailing of credentials.

Applications are available from:

Maryland Motor Vehicle  
Administration  
Motor Carrier Services Section  
Room 120  
6601 Ritchie Highway  
Glen Burnie, Maryland 21062

<http://www.mva.maryland.gov>

The annual IRP registration renewal cycles months are:
---

January
---------

April
-------

July
------

October
---------

## **SUPPLEMENTAL IRP APPLICATIONS**

If you have an existing IRP account you may process the following transactions on line to:

- Add a vehicle, or
- Transfer a vehicle, or
- Change the weight of a vehicle.

To perform this transaction, go to the MVA website:

<http://www.mva.maryland.gov/Resources/IRP-A-C.pdf>

Once your application is received, it will be processed and an invoice will be returned to the e-mail address on file.

## **IRP TRIP PERMITS**

Maryland registrants who are eligible for apportioned registration in other IRP jurisdictions, but have not registered their vehicle in the jurisdiction being entered must either add the required jurisdiction to their Maryland IRP registration or purchase an IRP Trip Permit before doing so.

Presuming you meet other requirements for the jurisdiction entered, and provided you possess an IRP Trip Permit, your vehicle is entitled to be operated intrastate and interstate (except in the jurisdictions below) for the period allowed under the terms of such a permit.

You should always contact the jurisdiction prior to entering to ensure intrastate operations are allowed.

**Intrastate operation is prohibited under a Trip Permit in the following states:**

- Iowa
- Kansas
- Nebraska

Vehicles from other IRP jurisdictions that are eligible for apportioned registration, but are not apportioned with Maryland will be required to either add Maryland to their current IRP registration or purchase a 72-hour IRP Trip Permit prior to entering the State.

The **"IRP Manual,"** is now available for viewing online at the MVA website:

[http://www.mva.maryland.gov/Resources/IRP\\_Manual.pdf](http://www.mva.maryland.gov/Resources/IRP_Manual.pdf)

If you have any questions regarding the IRP process, Trip Permits, and other concerns, please contact the MVA at the telephone numbers listed in Appendix C.

## CHAPTER VI

### INTERNATIONAL FUEL TAX AGREEMENT (IFTA)

#### What's Required – How Can I Obtain an IFTA Decal?

The International Fuel Tax Agreement (IFTA), is an agreement between all U.S. states, and Canadian provinces to simplify the reporting of fuel usage by interstate/inter-jurisdictional motor carriers.

#### IFTA Participants

- 48 continental US states
- Canadian provinces, except the following:
  1. Northwest Territory.
  2. Nunavut Territory.
  3. Yukon Territory.

**NOTE - The District of Columbia (DC) does not participate in IFTA.**

Maryland is your base jurisdiction for IFTA licensing and reporting if you:

- Have one or more qualified motor vehicles based in the state.
- Have an established place of business where motor carrier operations are conducted.
- Maintain operational control and operations records for qualified motor vehicles in the State.
- Have one or more qualified motor vehicles that actually travel on Maryland highways.
- Operate in at least one other jurisdiction.

Maryland does not charge an annual renewal processing fee for an IFTA license and does not charge a fee for IFTA decals. Maryland issues two IFTA decals that are required to be displayed on a vehicle. One decal is required to be affixed on the driver's side of the vehicle, and one decal is required to be affixed on the passenger's side.

**The minimum fine for failure to register or to display valid IFTA documents is \$230.**

You can contact any of the Comptroller's 12 service offices located throughout Maryland.

**NOTE:** Carriers who are required to display IFTA decals are required to display them on each side of each qualifying vehicle and have a cab card, or copy of the card located inside the vehicle. Carriers that qualify for an IFTA license but do not have IFTA approved decals and do not participate in the IFTA program, must obtain IFTA temporary Trip Permits to travel through member jurisdictions, according to the regulations and fees of each member jurisdiction. **A motor carrier operating exclusively in Maryland and D.C. must either have an IFTA license and decals OR a trip permit to operate within the State of Maryland.**

**Need an IFTA License –  
Contact:**

**Comptroller of Maryland  
Motor Fuel, Alcohol and  
Tobacco Tax Unit  
IFTA Program  
P.O. Box 1751  
Annapolis, MD 21401-1751  
Telephone # 410-260-7980  
Toll-free (within Maryland  
only) at 1-888-638-2937**

**Maryland based carriers should refer to the "[Maryland IFTA Compliance Manual](#)," for specific IFTA requirements and instructions. The manual is available for viewing online at the Comptroller's website at:**

**[http://compnet.comp.state.md.us/Motor\\_Fuel\\_\\_Alcohol\\_and\\_\\_Tobacco\\_Tax/Motor\\_Fuel\\_Tax/Static\\_Files/IFTA\\_Manual/ifta\\_manual.pdf](http://compnet.comp.state.md.us/Motor_Fuel__Alcohol_and__Tobacco_Tax/Motor_Fuel_Tax/Static_Files/IFTA_Manual/ifta_manual.pdf)**

## CHAPTER VII

### DISPLAY OF VEHICLE IDENTIFICATION

Every truck, truck tractor and bus operated on Maryland highways, except as provided, shall be identified on both sides of the vehicle with the name, or trade name of its owner, operator or lessee and display:

- A USDOT Number, or
- The number issued by a State agency.

#### A. USDOT NUMBER

Interstate transportation requires a USDOT Number.

How can I get a USDOT Number?

- Contact the Federal Motor Carrier Safety Administration (FMCSA) at 1-800-832-5660, or
- [www.fmcsa.dot.gov/factsfigs/formspubs.htm](http://www.fmcsa.dot.gov/factsfigs/formspubs.htm)

The requirement for the display of vehicle identification shall also comply with the "*Federal Motor Carrier Safety Regulations*, (FMCSR), *Part 390.21*."

#### B. MOTOR CARRIER (MC) NUMBER - OPERATING AUTHORITY

FMCSA enforces requirements for all interstate for-hire carriers to obtain an MC Number. FMCSA charges a fee for this number. The "operating authority" requirement is being enforced in Maryland and interstate for-hire carriers moving freight through the State without operating authority will be placed Out-Of-Service. To obtain an MC Number, call the FMCSA at the telephone number listed in Appendix C, or you can apply for an MC Number on-line at their website at:

<http://www.fmcsa.dot.gov>

### C. MARYLAND USDOT NUMBER

Motor carriers that are not required to have an interstate USDOT Number because their vehicles do not leave Maryland and do not transport interstate cargo are required to obtain and display a Maryland specific intrastate USDOT Number, or a number issued by a State agency in addition to the trade name, company name or owner/lessee's name on both sides of their vehicles.

<p><b>Vehicles that <u>must</u> display a MD USDOT Number/State issued number:</b></p> <ul style="list-style-type: none"><li>• Trucks registered over 10,000 pounds</li><li>• Truck-tractors</li><li>• Buses</li></ul>	<p><b>Vehicles exempt from obtaining a MD USDOT Number:</b></p> <ul style="list-style-type: none"><li>• Vehicles already displaying a USDOT Number</li><li>• Vehicles registered as Farm Trucks or Farm Truck Tractors</li><li>• Vehicles registered as Farm Area Vehicles</li><li>• Trucks registered at 10,000 pounds capacity or less</li><li>• Emergency vehicles</li><li>• Vehicles used primarily to transport money or commercial paper*</li><li>• Vehicles owned by the State, or local government</li><li>• Vehicles within 15 days of their purchase</li></ul>
--	--

\*The term "commercial paper," for the purposes of vehicle identification means, "money market security issued by large banks and corporations." **Commercial paper does not include transporting newspapers, stationary, etc.** Maryland specific intrastate USDOT Numbers can be obtained free of charge by filing an application with the Maryland State Highway Administration, Motor Carrier Division (SHA/MCD). Applications are available at all Maryland Truck Weigh and Inspection Stations (TWIS), or can be obtained on line at the SHA website:

[http://www.roads.maryland.gov/OOTS/Mcir150\\_all\\_1.pdf](http://www.roads.maryland.gov/OOTS/Mcir150_all_1.pdf)

If you have further questions regarding this matter, please call the SHA Motor Carrier Division telephone numbers listed in Appendix C.

**D. AUTHORITY FROM THE PUBLIC SERVICE COMMISSION (PSC)**

Intrastate operators of any motor vehicle transporting passengers for hire must secure a permit from the PSC.

For more information, contact the PSC at the following address:

Maryland Public Service Commission  
William Donald Schaefer Tower  
Transportation Division  
6 St. Paul Street  
Baltimore Maryland 21202  
Telephone # 410-767-8128

## CHAPTER VIII

### DRIVER'S LICENSING REQUIREMENTS

#### A. GENERAL RULES

Every person driving a motor vehicle must have in their possession a valid driver's license of the appropriate class, except those expressly exempted. Under specific conditions, if you wish to drive a commercial motor vehicle (CMV), you will be required to obtain a Commercial Driver's License (CDL) and have it in your possession when operating any motor vehicle. Specific conditions apply.

A person who is licensed in another state and establishes residency in Maryland is required to obtain a Maryland driver license within 60 days. **Within 30 days of establishing a residence in this State, the holder of a CDL shall apply for a Maryland CDL.**

For additional information, call the MVA telephone numbers listed in Appendix C, or visit their website at:

<http://www.mva.maryland.gov>

## B. COMMERCIAL DRIVER'S LICENSE (CDL)

For the purposes of the CDL requirement in Maryland, a "commercial motor vehicle" (CMV) means:

1. A motor vehicle with a gross vehicle weight rating (GVWR) of 26,001 pounds or more;
2. A combination of vehicles with a gross combination weight rating (GCWR) of 26,001 pounds or more if the GVWR of the vehicles being towed are in excess of 10,000 pounds;
3. Any vehicle which is designed to transport 16 or more passengers, including the driver;
4. A vehicle of any size and is used in the transportation of materials found to be hazardous for the purposes of the "Hazardous Materials (Haz-Mat) Transportation Act," and which requires the motor vehicle to be placarded under hazardous materials regulations ("49 CFR Part 172, Subpart F"). (Reference source: "The Maryland Vehicle Law, Title 16, §803(c)(iv).")

**Remember:** For the purposes of determining if a CDL is required regarding weight, the following applies:

**Gross Vehicle Weight Rating (GVWR) means:**

- The value specified by the vehicle manufacturer as the loaded weight of a single vehicle

**Gross Combination Weight Rating (GCWR) means:**

- The value specified by the manufacturer as the loaded weight of a combination or articulated vehicle, or
- In the absence of a value specified by the manufacturer, the GCWR shall be determined by adding the GVWR of the power unit and the total weight of the towed vehicle and its load.

The definition for a CMV does not include the following for the purposes of a CDL. However, a driver who is operating any of the vehicles listed below must have a Non-Commercial Driver's License with the appropriate license class:

**a. A vehicle controlled and operated by a farmer:**

- Used to transport agricultural products, farm machinery, or farm supplies to or from a farm
- Not used in the operations of a common or contract motor carrier, and
- Used within 150 miles of the person's farm.

**b. An emergency vehicle:**

- Equipped with audible and visual signals, and
- Operated by a member of, or a person in the employ of a volunteer or paid fire or rescue organization.

**c. A vehicle owned or operated by the United States Department of Defense if it is controlled and operated by:**

- Any active duty military personnel, or
- Any member of the military reserves, or National Guard on active duty, including personnel on full-time National Guard duty and personnel on part-time training, or
- Any National Guard Military Technician (NGMT).

**d. A motor vehicle designed and constructed primarily to provide temporary living quarters for recreational, camping, or travel use.**

### C. AGE REQUIREMENTS FOR A CDL

<p>At age 18 with the proper Class of CDL:</p> <ol style="list-style-type: none"><li>1. I am allowed to drive only in Maryland.</li><li>2. I cannot drive interstate.</li><li>3. I cannot drive a vehicle hauling Hazardous Materials (Haz-Mat).</li><li>4. I cannot drive a School Bus.</li></ol>	<p>At age 21 with the proper Class of CDL:</p> <ol style="list-style-type: none"><li>1. I can drive both intrastate and interstate.</li><li>2. I can drive the following vehicles <u>ONLY</u> when I have the appropriate endorsement on my CDL:<ul style="list-style-type: none"><li>• Tank Vehicle</li><li>• Vehicle carrying Haz-Mat</li><li>• School Bus</li><li>• Vehicle carrying passengers (16 or more including the driver)</li><li>• Double combinations</li></ul></li></ol>
--	--

Note: **Interstate** transport is the pick-up or delivery of cargo originating or destined outside the State of Maryland (pier freight, air freight and some warehouse freight can be interstate cargo). **Intrastate** transport is the pick-up or delivery of cargo originating and destined within the State of Maryland.

## Commercial Driver's License (CDL) Requirements

CDL Applicant's current license status	MD Law Test	CDL Knowledge Test(s)	CDL Instructional Permit	CDL Skills Test	Remarks
No License	Yes	Yes	Yes	Yes	
Non-commercial Maryland Driver's License or lower class CDL	No	Yes	Yes	Yes	
Existing MD License – Converting to CDL of same class	No	Yes	Yes	Yes	CDL skills tests may be waived by MVA
Out-of-state Driver's License (Non CDL)	No	Yes	Yes	Yes	Drivers will be required to obtain an instructional permit
Out-of-state CDL of same class	No	See remarks	No	No	Haz-Mat test required to be taken when converting out of state CDL to MD, and required at renewal, and whenever Haz-Mat endorsement is being added to CDL
Out-of-state CDL of lower class	No	Yes	Yes	Yes	

All applicants must pass a vision-screening test. To prepare for the written Maryland Law Test, you should obtain and read the "[Maryland CDL Handbook](#)."

**A vehicle and trailer used for testing purposes (CDL) must have the manufacturer's plate on the vehicle and trailer. This plate is normally located inside the door frame on the driver's side of the vehicle and on the front of the trailer. The manufacturer's plate (label) provides the gross vehicle weight rating (GVWR) for the vehicle and in some instances provides the gross combination weight rating (GCWR) or towing capacity for the vehicle as well.**

## D. THE CDL DRIVING TEST

CDL examinations are conducted at various MVA locations. **The skills test is conducted by appointment only!** You must apply in person at a full service MVA branch office to go through the process for obtaining a CDL. The applicant **must** present a current medical examiner's certificate (DOT physical) prior to taking any CDL knowledge test(s) and **must** take and successfully pass all written tests. You may obtain information concerning locations, dates and business hours at:

<http://www.mva.maryland.gov>

**\*NOTE: CDL skills tests are not given at all locations.**

**The applicant is required to supply a registered motor vehicle in safe operating condition of a type to test the applicant's ability to drive all vehicles under that class of CDL.** . (Refer to the chart on the next page)

Class "A", and "B" or "C" with passenger endorsement will require a CDL skills test, which consists of a pre-trip inspection, on course maneuvers and public road test. You must successfully pass the pre-trip inspection before moving onto the course maneuvers. Further, you must successfully pass the course maneuvers test before moving onto the public road test. All of the tests are designed to assess your driving ability, knowledge and observance of traffic laws.

**A driving skills test will not be conducted in a vehicle with defective equipment.** While driving with a learner's instructional permit, you must be accompanied by a person properly licensed to drive vehicles of that class or higher class who has at least three years driving experience and is at least 21 years of age.

When appearing for your driving skills test, you must be accompanied by a person who is properly licensed to drive vehicles of that class, or you may be driven to the location where the testing will be performed by a person who meets the conditions as previously listed.

**If you have any questions call the MVA telephone numbers listed in Appendix C, or contact them at:**

<http://www.mva.maryland.gov>

**Driving Test for CDL – Vehicle Type Required**

CDL - Class "A"	Truck tractor/trailer (Class "F" truck tractor and Class "G" semi-trailer) equipped with air brakes is the preferred motor vehicle.  Other vehicle combinations with a GCWR of 26,001 pounds or more may be used if the towed vehicle has a GVWR in excess of 10,000 pounds.*  If a combination other than an air brake equipped vehicle is used, your license will be restricted to vehicles without air brakes.**
CDL – Class "B"	A vehicle with a GVWR of 26,001 or more pounds.**
CDL – Class "C"	A vehicle with a GVWR of less than 26,001 pounds.**

**NOTE:** You may be issued a Class "M" (motorcycle) license with any other License. However, you will be issued only one license – for example, on the face of the CDL it would show A M, indicating you can drive any vehicle in either Class A, B, C, or a motorcycle.

\*For this combination you will be issued a Class "A" CDL; however, you will have an "O" restriction on it indicating you are not allowed to drive a truck tractor-semi-trailer combination.

\*\* If you take the test using a vehicle without air-brakes, you will have an air-brake restriction placed on your CDL indicating **you will not be allowed to drive air-brake equipped vehicles.**

## Maryland Commercial Driver's Licenses

With this Class	You may drive	And may tow	You may not drive the following listed vehicles
<b>A</b>	Any single vehicle or combination of vehicles*	Any trailer*	<ul style="list-style-type: none"> <li>• Motorcycles</li> </ul>
<b>B</b>	Motor vehicles 26,001 or more pounds (GVWR)*	Trailers not in excess of 10,000 pounds GVWR*	<ul style="list-style-type: none"> <li>• Combinations of Class "F" truck tractor and Class "G" trailer</li> <li>• Motor vehicles with a GVWR 26,001 pounds or more</li> <li>• Combinations of vehicles where the GCWR is 26,001 pounds or more if the GVWR of the vehicle being towed is in excess of 10,000 pounds</li> <li>• Motorcycles</li> </ul>
<b>C</b>	Motor vehicles less than 26,001 pounds (GVWR)*	Trailers not in excess of 10,000 GVWR	<ul style="list-style-type: none"> <li>• Combinations of Class "F" truck tractor and Class "G" trailer</li> <li>• Motor vehicles with a GVWR 26,001 pounds or more</li> <li>• Combination of vehicles with a GCWR of 26,001 pounds or more</li> <li>• Motorcycles</li> </ul>

**\*Notes: Endorsements are required for Tank Vehicles, Doubles, Hazardous Materials, Passengers, and School Buses. Refer to the next page.**

## E. SPECIAL ENDORSEMENTS FOR CDL'S

A special endorsement is required on the CDL to drive any of the following listed vehicles.

### Special Endorsements

- **N** - Any vehicle designed to transport any liquid or gaseous material within a tank that is either permanently or temporarily attached to the vehicle or chassis. This does not include portable tanks having a rated capacity under 1,000 gallons
- **P** - Passenger vehicles – 16 or more passengers including the driver
- **S** - School Bus
- **T** - Double trailer combination
- **H** - Vehicles transporting Hazardous Materials (Haz-Mat) which requires placarding
- **X** - N and H combined

## Commercial Driver's License (CDL)

### CDL ENDORSEMENTS

#### Double/Triple Trailers (T)

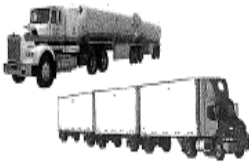

#### Passenger Vehicles (P)



#### Tank Vehicles (N)

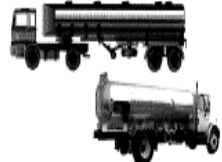

#### Hazardous Materials (H) (any size vehicle)



#### School Buses (S)



#### Tank & Hazardous Materials (X)



Federal Motor Carrier  
Safety Administration



U.S. Department of Transportation  
[www.fmcsa.dot.gov](http://www.fmcsa.dot.gov)

## F. HAZARDOUS MATERIALS (Haz-Mat) ENDORSEMENTS

Any CDL driver seeking to add a Haz-Mat endorsement to their CDL, or renewing a CDL that has an existing Haz-Mat endorsement, or possessing a CDL with a Haz-Mat endorsement issued by another state and seeking to obtain a Maryland CDL with a Haz-Mat endorsement is subject to a background check and other processes as required by the "U.S. Patriot Act of 2001." For additional information, visit the MVA website at:

<http://www.mva.maryland.gov>

## G. DRIVER'S RESPONSIBILITY

**All commercial drivers must do the following:**

1. Notify their employer of any convictions of motor vehicle laws, other than parking violations, within 30 days of the date of conviction; and
2. Notify their employer of any revocation, suspension, cancellation or disqualification, before the end of the business day following the day that the driver received notice of the fact; and
3. Provide any new employer with a 10 year employment history and a three year driving history; and
4. Turn in all driver's licenses issued by any other state or jurisdiction.

**All CMV drivers who fit the criteria listed in item B1, B2, B3, and B4 of this section must have in their possession when driving a CMV a valid CDL for the class of vehicle being driven, and current medical examiner's certification (DOT physical).**

## H. NON-COMMERCIAL DRIVER'S LICENSE

Non-commercial Class "A" and "B" Driver's License examinations are conducted at various MVA locations by appointment only! You may obtain information regarding locations, dates and business hours from any branch office or at:

<http://www.mva.maryland.gov>

The applicant is required to supply a registered motor vehicle in safe operating condition of a type to test the applicant's ability to drive all vehicles under that class of Non-commercial Driver's License. Non-commercial Class "A" and "B" Driver's License tests will include a pre-trip equipment inspection by the applicant in the presence of an MVA Driver's License Examiner.

**A driving skills test will not be conducted in a vehicle with defective equipment.** While driving with a learner's instructional permit, you must be accompanied by a person properly licensed to drive vehicles of that class or higher class who has at least three years driving experience and is 21 years of age.

When appearing for your driving skills tests, you must be accompanied by a person who is properly licensed to drive vehicles of that class, or you may be driven to the location where the testing will be performed by a person who meets the conditions as previously listed.

Drivers of Non-CDL type commercial vehicles that have a GVWR or GVW of 10,001 pounds up to 26,000 pounds are required to be physically qualified to drive them. In this case, a driver must have in their possession a current medical examiner's certification (DOT physical) card or a copy of the card.

**Driving Test for a Non-commercial Driver's License -  
Vehicle Type Required**

Non-commercial Class "A"	Non-commercial truck tractor (Class "F" vehicle) and trailer (Class "G" vehicle).
Non-commercial Class "B"	Non-commercial motor vehicle with a gross vehicle weight rating (GVWR) 26,001 pounds or more, or a combination of vehicles (except a Class "F" truck tractor and Class "G" trailer), which has a gross combination weight rating (GCWR) of 26,001 pounds or more.
Non-commercial Class "C"	Automobile, station wagon, light truck, or any non-commercial motor vehicle with a GVWR of less than 26,001 pounds.
Non-commercial Class "M"	Motorcycle.

**Non-commercial Driver's License**

With this Class	You may drive	And may tow	You may not drive the following listed vehicles.
<b>A</b>	Any Non-commercial vehicle	Any Non-commercial trailer	<ul style="list-style-type: none"> <li>• Commercial motor vehicles</li> <li>• Motorcycles</li> </ul>
<b>B</b>	Any single Non-commercial vehicle with a GVWR of 26,001 pounds or more, or combination of vehicles with a GCWR of 26,001 pounds or more	Any Non-commercial trailer	<ul style="list-style-type: none"> <li>• Commercial motor vehicles</li> <li>• Class "F" truck tractor in combination with a Class "G" trailer</li> <li>• Motorcycles</li> </ul>
<b>C</b>	Any single Non-commercial vehicle with a GVWR of less than 26,001 pounds or combination of vehicles with a GCWR of less than 26,001 pounds	Any Non-commercial trailer as long as the vehicle combination GCWR is less than 26,001 pounds	<ul style="list-style-type: none"> <li>• Commercial motor vehicles</li> <li>• Class "F" truck tractor &amp; Class "G" trailer</li> <li>• Vehicles and vehicle combinations where the GVWR is 26,001 pounds or more</li> <li>• Motorcycles</li> </ul>
<b>M</b>	Motorcycles	M/C trailer	Any other vehicle

## **I. QUESTIONS**

If you have any questions regarding either CDL or Non-Commercial Driver's License requirements for vehicles, or where the MVA Branch Offices are located, call the MVA telephone numbers listed in Appendix C.

Or visit their website at:

<http://www.mva.maryland.gov>

## **J. SUSPENSIONS/REVOICATIONS/DISQUALIFICATION**

### **1. Suspensions**

Suspension of a Maryland driver's license and/or privilege means to temporarily withdraw the privilege to operate a motor vehicle. Periods of suspension vary under specific circumstances. Should you have questions as to your driving status, visit an MVA office in your area or call the MVA telephone numbers listed in Appendix C.

### **2. Revocations**

Revocation of a Maryland's driver's license and/or privilege means to temporarily withdraw your privilege to operate a motor vehicle. Similar to the suspension process the revocation of a driver's license and/or driving privilege is considered more serious in nature. Periods of revocation vary.

### **3. Disqualification**

This term normally applies to instances where a person is disqualified from driving a CMV. Periods of disqualification can vary; however, for some offenses/violations the period of disqualification can be for life.

When a Maryland driver's license and/or driving privilege is refused, canceled, suspended or revoked, the license and/or driving privilege is terminated. The person is not permitted to drive a motor vehicle under ANY circumstances. Similarly, if a person has been disqualified in Maryland from driving a CMV, the person may not drive a CMV under ANY circumstances.

**\*NOTE- Some serious violations committed in your personal car may disqualify you from driving a CMV.**

**If your license is refused, canceled, suspended, or revoked in any state or jurisdiction, you are not allowed to drive any vehicle in Maryland under any circumstances. If you have been disqualified from driving a CMV in any state or jurisdiction, you are not allowed to drive a CMV in Maryland under any circumstances.**

For reinstatement procedures, visit an MVA branch office in your area, or call the MVA telephone numbers listed in Appendix C.

## CHAPTER IX

### INSURANCE REQUIREMENTS

#### A. INTRASTATE OPERATIONS

##### 1. FOR CARRIERS OF FLAMMABLES:

Liability Insurance - for each vehicle - \$1,000,000 combined single limit for each accident. Cargo Insurance – for loss of or damage to property carried on any one vehicle - \$5,000; and for loss of, or damage to aggregate loss or damages of or to property occurring at any one time and place - \$10,000.

##### 2. FOR CARRIERS OF PASSENGERS:

Liability Insurance:

- A. The minimum per accident insurance required for each vehicle with a seating capacity of 7 PASSENGERS OR LESS is \$50,000 for injury to one person, \$100,000 for injuries to two or more persons, and \$20,000 for property damage OR \$120,000 combined single limit,
- B. The minimum per accident insurance required for each vehicle with a seating capacity of BETWEEN 8 AND 15 PASSENGERS is \$75,000 for injury to any one person, \$200,000 for injuries to two or more persons, \$50,000 for property damage OR \$250,000 combined single limit, and
- C. Minimum per accident insurance required for each vehicle with a seating capacity of 16 PASSENGERS OR MORE is \$75,000 for injury to any one person, \$400,000 for injuries to two or more persons, and \$100,000 for property damage OR \$500,000 combined single limit.

## **B. INTERSTATE OPERATIONS**

Proof of insurance (Form MCS-90) shall be maintained at the motor carrier's principle place of business. Public liability coverage is:

- \$ 750,000 for non-hazardous property hauling
- \$1,000,000 for oil hauling
- \$5,000,000 for hazardous substances hauling
- \$1,500,000 for less than 16 passengers
- \$5,000,000 for 16 or more passengers

**Effective January 1, 2011, Maryland began enforcing the provisions of the FMCSR, Part 387, regarding the required levels of insurance for interstate carriers operating in the State.**

**Commencing January 1, 2012, Maryland will begin enforcing the provisions of the FMCSR, Part 387 (levels of insurance) for vehicles that are over 26,000 pounds GVW operated by intrastate for-hire carriers of property. For further information/assistance, call the SHA Motor Carrier Division at 410-582-5734, or toll-free 800-543-4564 (within Maryland only), or the Maryland Motor Truck Association (MMTA) at 410-644-4600.**

## CHAPTER X

### **COMMERCIAL VEHICLE INFORMATION SYSTEMS AND NETWORKS (CVISN)**

CVISN (pronounced "see vision") is a coordinated program administered by the Federal Motor Carrier Safety Administration (FMCSA). CVISN involves federal and state agencies, and the motor carrier industry (truck and motor coach) utilizing technology to streamline licensing and registration requirements for motor carriers, and allows safety compliant companies to by-pass Truck Weigh and Inspection Stations (TWIS).

In the CVISN process, commercial motor vehicles (CMV's) equipped with electronic transponders (small transmitters) send data to a roadside operations computer (ROC) which is installed inside the TWIS. The ROC is monitored by enforcement personnel who staff the TWIS. Weigh-in-motion (WIM) devices located on both the main-line and ramp entrances to the TWIS measure the weight of each vehicle. This information is then electronically forwarded to the ROC.

Since enforcement personnel are able to quickly review the data on multiple vehicles, this process enables them to concentrate on carriers with poor safety ratings and those CMV's not equipped with transponders and direct them to the static scale for weighing and for closer examination. The entire process is called "Electronic Screening" or E-Screening (ES).

In the ES process, carriers who have a good safety rating and whose vehicles are within vehicle weight limitations (axle, gross, bridge, etc.), and are equipped with a transponder, may be able to bypass the TWIS and continue on their journey. Those carriers without transponder equipped vehicles will be required to enter the TWIS.

Components of CVISN include:

- **Interstate Credential Administration**

Uses a web/Internet site that motor carriers can use to submit, request and pay for credentials such as IRP and IFTA. In the future, online processing of Oversize/Overweight Hauling Permits will be added. These functions will streamline the credential application process.

- **Safety Information Exchange**

Provides motor carrier safety inspectors with accurate and timely information where data is used to determine if a safety inspection needs to be conducted at the TWIS or at roadside. In the long run, this saves time for inspectors and motor carriers because it focuses on non-compliant carriers and enables compliant carriers to by-pass the TWIS.

- **Roadside Electronic Screening (ES)**

This process allows compliant carriers to by-pass a TWIS and focuses more on non-compliant carriers.

## **A. CURRENT CVISN APPLICATIONS**

In Maryland, ES has been implemented and installed at the following TWIS:

- S/B I-95 – Perryville TWIS
- W/B I-70 – West Friendship TWIS
- E/B I-70 – New Market TWIS
- N/B I-270 – Hyattstown TWIS
- S/B I-270 – Hyattstown TWIS

All sites are classified as Phase 3, incorporating pre-screening on the basis of weight, over height vehicles, safety and credentials violations. The WIM utilizes a Lineas Quartz-digital sensor which has been customized with automatic correlation and calibration software that keeps the sensor within the American Society for Testing and Materials (ASTM) specifications by comparing the in-motion truck weights with weights derived at the static scale.

## **B. TRANSPONDERS - HOW CAN I PARTICIPATE IN THE PROGRAM?**

If you wish to participate in the Maryland E-screening Program, go to the PrePass website at:

<http://www.prepass.com/Pages/Home.aspx>

To obtain an E-ZPass dual-use transponder (which can be used for E-Screening via PrePass and Maryland CVISN E-screening), please contact the E-ZPass Maryland Customer Service Center at 1-888-321-6824 (toll-free).

## **C. CVISN – THE FUTURE**

CVISN is an evolving program. New and innovative enhanced technologies are constantly being examined and tested. These include Virtual Weigh Stations, thermal (or infrared) imaging for brake and axle component visualization, and license plate and USDOT Number reader technology for future applications. All of these technologies have the potential to streamline and upgrade both the regulatory and motor carrier processes, which will make it easier to do business in Maryland and enhance highway safety.

You can find more information about CVISN on the FMCSA website:

<http://www.fmcsa.dot.gov>

## CHAPTER XI

### SAFE VEHICLE OPERATIONS

#### A. VEHICLE CONTROL

Exercising the safe control of a vehicle as it is being operated on highways in Maryland is the responsibility of the driver. Safe operation of a vehicle not only saves time, but it saves lives.

##### 1. Driving loaded vehicle down long hills or steep grades:

- Control the speed of your vehicle by shifting to a lower gear at the top of the hill
- Brake smoothly while proceeding downward
- Do not pump the brake pedal, but apply constant, even pressure

##### 2. Approaching off-ramps:

When approaching exit-ramps, slow the speed of your vehicle and use caution upon entering and traveling through the ramp. Not all exit-ramps are the same. Some have sharper turns than others, so please use caution.

#### B. LOAD SECUREMENT

When transporting logs, poles, lumber, pipe, or steel on an open bed truck or trailer you are required to at a minimum:

- Securely fasten them to the vehicle at the front and rear of the load with approved tie-downs to include two chains or other approved fastening devices with equal tensile strength around the front and rear of the load. The chains must be at least ½ inch in diameter, common coil B.B. chains for loads over 3 tons, and 3/8 inch diameter for 3 tons or less.

Other fastening devices for use include 5/16-inch diameter wire rope, synthetic fiber webbing and steel strapping.

**Additional load securement requirements apply and information concerning these can be found in the "Federal Motor Carrier Safety Regulations (FMCSR), Part 393.100." For additional information or guidance, you should consult the FMCSR, Part 393.100 through 136. If you still have questions, please call either the SHA Motor Carrier Division at 410-582-5734 or toll-free (within Maryland only) at 1-800-543-4564, or the MSP/CVED at 410-694-6100.**

If a load extends over the rear of a vehicle more than 4 feet or over 6 inches beyond either side of the vehicle, a red or orange fluorescent flag at least 18 inches square and a red light are required to mark the extremities of the load. (Oversize Hauling Permit restrictions may also apply – refer to Chapter XIII)

Spillage or residue left on the vehicle due to loading or unloading must be removed from any non-load-carrying parts of the vehicle prior to it being driven on a highway in Maryland. The tailgate must be securely fastened and the bed may not have holes or openings through which material can escape.

### **C. BRAKING SYSTEMS – Maintenance & Safety**

Every vehicle shall have a service braking system that will enable the driver to bring the vehicle to a safe stop and hold it no matter what its load on any grade on which it is operated that is free of ice and snow.

A vehicle's braking system is one of the most critical components on a vehicle. When properly maintained, the braking system will assure adequate braking force is available for use by the driver to slow the speed of a vehicle and bring it safely to a stop. On the other hand, a poorly maintained system is a disaster waiting to happen. **Your life and the lives of other motorists are at risk if you fail to check and maintain your vehicle's brake system, and assure that it is in proper working order.**

Under normal operating conditions on a vehicle equipped with an air-brake system, the driver should not rapidly pump the brake pedal up and down, as this will reduce air pressure below the minimum pressure needed for safe operation.

If the air pressure in the brake system drops below a safe operating level, a low-pressure warning device will activate alerting the driver of a brake problem. When this happens, the driver should stop the vehicle as quickly and as safely as possible and not drive it until the braking system has been repaired.

The braking system for a multiple vehicle combination shall be equipped with an emergency valve to activate the trailer/semi-trailer brakes immediately in case the trailer or semi-trailer detaches or becomes detached from the towing unit while the combination is traveling on a highway.

#### **D. DISABLED VEHICLES**

If your vehicle becomes disabled, move it off the road to a safe area as soon as possible. Once off the roadway place the necessary warning flares, reflectors or other signal devices on the side facing approaching/oncoming traffic.

**\*\*DANGER\*\***

**Vehicles carrying explosives, or a cargo tank truck carrying flammable liquids, compressed gases, or a motor vehicle using compressed gas as a fuel are not allowed to carry:**

- A flare, or
- Fusee, or
- Signal produced by flame.

## Where do I place the emergency breakdown safety devices?

<p>On undivided or one lane roadways, three flares or warning devices must be placed:</p> <ul style="list-style-type: none"><li>• One beside the vehicle</li><li>• One 100 feet behind the vehicle</li><li>• One 100 feet ahead of the vehicle</li></ul>	<p>On divided highways or one-way highways, place the three warning devices behind your vehicle facing the traffic side at the following locations :</p> <ul style="list-style-type: none"><li>• One 10 feet behind</li><li>• One 100 feet behind</li><li>• One 200 feet behind</li></ul>
--	---

<p><b>DO:</b></p> <ul style="list-style-type: none"><li>• Place break-down safety devices as required to warn approaching motorists as soon as possible</li><li>• If you have a telephone, call for assistance</li><li>• Make arrangements to remove your vehicle as soon as possible</li></ul>	<p><b>DON'T :</b></p> <ul style="list-style-type: none"><li>• Leave your vehicle on the road without placing safety devices</li><li>• Leave your vehicle on the side of the road without making arrangements to have it removed as soon as possible</li><li>• Park or leave your disabled vehicle on the shoulder of the road for an indefinite period of time</li></ul>
---	--

**NOTE:** Inoperable vehicles, motor vehicles, trailers, semi-trailers, and buses will be considered abandoned and will be towed at the owner's expense when left unattended on:

- 1) Public highways for more than 48 hours\*, or
- 2) A controlled access highway for more than 24 hours\*, and
- 3) Toll roads under the jurisdiction of the Maryland Transportation Authority for more than 12 hours.\*

**\*Abandoned vehicles that pose a traffic hazard may be towed immediately.**

**"A PERSON MAY NOT STOP, STAND, OR PARK A VEHICLE ON ANY ENTRANCE OR EXIT RAMP OF ANY HIGHWAY WITH TWO OR MORE LANES FOR TRAFFIC MOVING IN THE SAME DIRECTION." (*The Maryland Vehicle Law, Title 21, §1003 (k)*)"**

## CHAPTER XII

### VEHICLE SIZE & LOADS

#### A. MAXIMUM WIDTH – MEASURING - LIMITS EXPLAINED - EXCEPTIONS

The width of a vehicle includes any load that it carries, but is exclusive of safety and energy conservation devices, such as side mirrors, turn signal lamps, marker lamps, steps and handholds for entry or egress, flexible fender extensions, mud-flaps and spray suppressant devices and load induced tire bulges. Except for side mirrors, no other safety or energy conservation device shall extend more than 3 inches on each side of the vehicle.

The width of a motor home or travel trailer shall be exclusive of retractable awnings installed by the vehicle manufacturer or dealer, provided that the awnings do not extend more than 6 inches from each side of the vehicle.

The maximum vehicle or vehicle combination width limit in Maryland is 102 inches (8 feet 6 inches). Certain roadways in the State may be posted by traffic signs prohibiting travel by 102 inch vehicles – i.e., I-895 Baltimore Harbor Tunnel where the maximum allowable vehicle/combination width is 96 inches (8 feet).

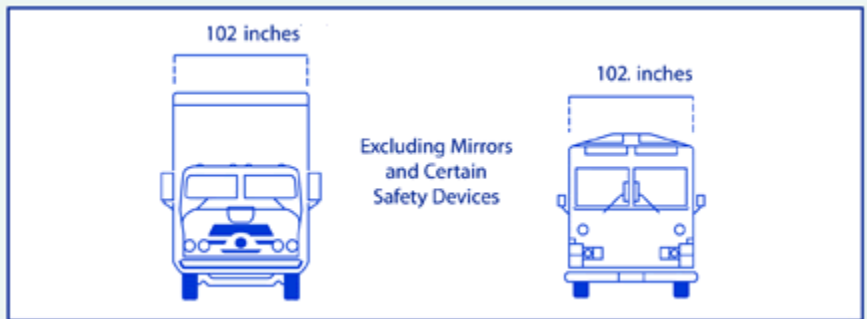

Vehicles and/or combinations that exceed 102 inches in width are required to obtain an Oversize Hauling Permit. For additional information, call the Maryland State Highway Administration's Hauling Permit Unit telephone numbers listed in Appendix C or you can email the Unit at:

[haulingpermits@sha.state.md.us](mailto:haulingpermits@sha.state.md.us)

Or

[MdMotorCarrier@sha.state.md.us](mailto:MdMotorCarrier@sha.state.md.us)

## **B. MAXIMUM HEIGHT**

- Maximum allowable height: **13'6"**

**Height detectors are installed at several TWIS as well as facilities owned by the MDTA – e.g. Baltimore Harbor Tunnel, Fort McHenry Tunnel, and elsewhere.**

## **C. LENGTH – How to measure - Exceptions**

The length of a vehicle includes its front and rear bumpers and any part of its load that extends beyond the vehicle. Not included, when measuring length, are non-load-bearing safety and energy conservation devices, such as marker lamps. The overhang of transported vehicles or boats such as on an auto carrier [3 feet to front, 4 feet to rear] is also not included. The load on the rear of an automobile transporter including any retractable device on the rear of a combination of vehicles engaged in the transportation of automobiles in use to support a transported vehicle, may not extend more than 4 feet beyond the rear of the bed or body of the automobile.

**Refer to the next page for the maximum allowable vehicle length limits.**

# 1. MAXIMUM LENGTH LIMITS FOR SINGLE UNIT TYPE VEHICLES – A QUICK GUIDE

Single unit truck or bus:	40'
Travel trailer:	40'
Publicly owned rigid bus:	41'
Class "M" motor home:	45'

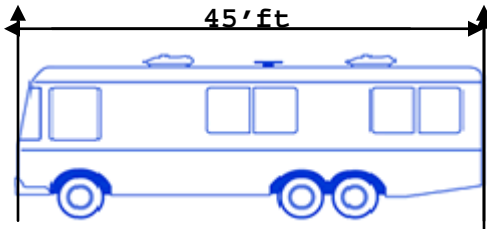

Class "M" motor home

Bus operated on highway part of the Interstate System or State Primary System:	45'
Publicly owned articulated three-axle bus:	60'
Other vehicles:	35'

## 2. MAXIMUM LENGTH LIMITS FOR COMBINATIONS OF VEHICLES

Any other combination of vehicles  
other than those listed: **55'**

Cargo carrying power unit in  
combination with another vehicle: **62'**

Combination of non-commercial power  
unit and travel trailer: **65'**



**Single Unit Truck Pulling a Trailer (Example)**

Maxi-cube vehicle consisting of  
non-articulating straight truck  
with a semi-trailer that does not  
exceed 34': **65'**

Truck, or truck tractor-semi-trailer combination designed for and engaged exclusively in the transportation of automobiles or boats:

65'

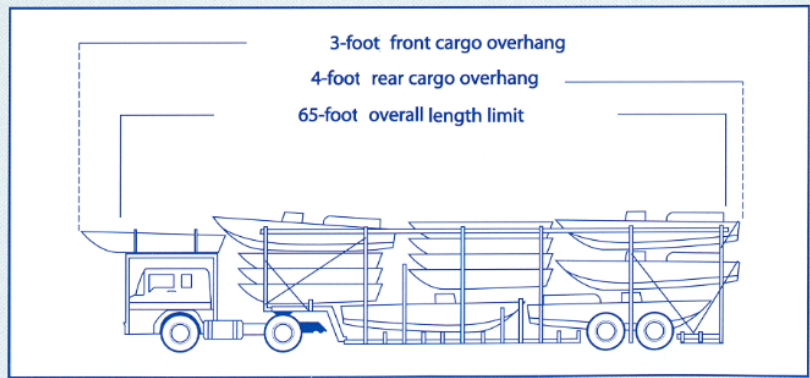

**Automobile/Boat Transporter (Example)**

Stinger-steer combination consisting of a truck tractor-semi-trailer carrying automobiles, or boats:

75'

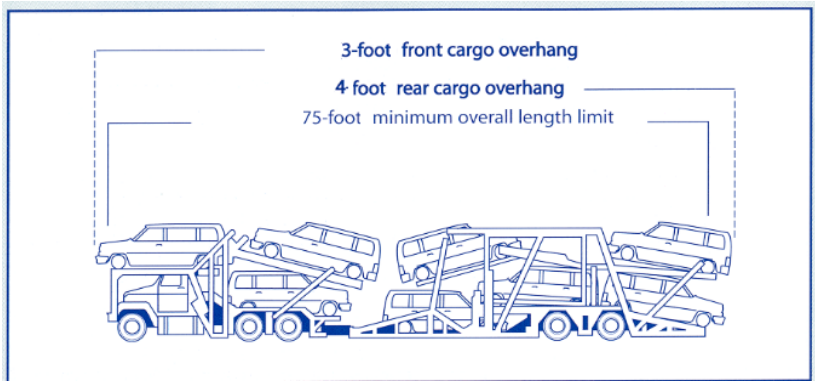

**Stinger-Steer Automobile Transporter (Example)**

Saddle-mount or full-mount combination

97'

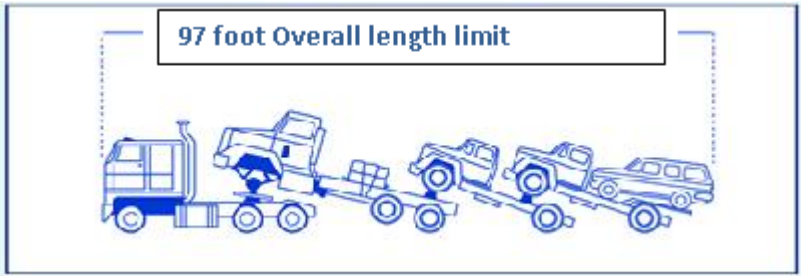

**Saddle Mount (Example)**

### **Exceptions to Length Limitations**

A combination of a semi-trailer and a trailer (double) being operated in combination with a non-cargo carrying truck tractor is not restricted to an overall length; however, the semi-trailer and trailer operated in this combination may not exceed 28 feet in length for each unit. This vehicle combination is restricted to operating on the Maryland National Network System of Highways. (Refer to Chapter II)

Vehicles or combination of vehicles carrying piling, poles, mill logs or crew or racing shells are exempt, as are a combination of vehicles carrying an indivisible load, if the load is not over 70 feet long and is traveling during daylight hours.

### 3. SEMI-TRAILERS EXCEEDING 48 FEET IN LENGTH UP TO A LENGTH NOT TO EXCEED 53 FEET – OPERATING RESTRICTIONS

A person may operate a semi-trailer (single) in combination with a truck tractor that exceeds 48 feet in length up to a length not to exceed 53 feet, but travel for this combination is limited to specific routes. Additional restrictions apply.

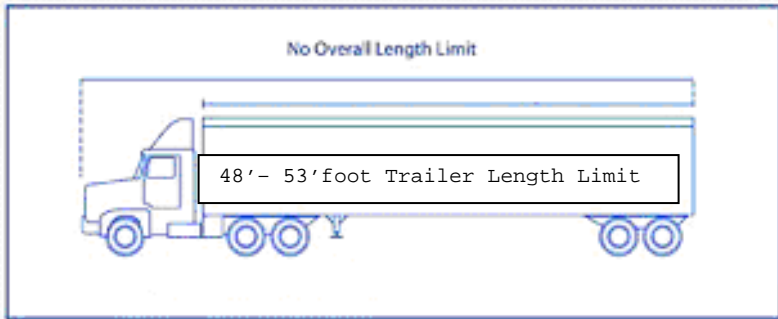

The following conditions apply:

- **Travel is restricted to the Maryland National Network System of Highways and the shortest practical route between a designated highway and a truck terminal, port, or point of origin or destination. Refer to Chapter II for approved routes and additional restrictions.**
- The wheelbase of the semi-trailer, measured as the distance from the kingpin to the center of the rear tandem axles, may not exceed 41 feet in length.
- The kingpin setback, measured as the distance from the kingpin to the front of the semi-trailer may not exceed 4 feet in length.
- The rear overhang, measured as the distance from the center of the rear tandem axles to the rear of the semi-trailer, may not exceed 35 percent of the wheelbase of the semi-trailer.
- The width of the semi-trailer shall be at least 96 inches and not more than 102 inches.

- The distance between the outside edges of the semi-trailer's tires shall be equal to the width of the semi-trailer.
- a. The semi-trailer shall be equipped with:
  - (1) Vehicle lights which comply with or exceed federal standards; and
  - (2) Reflective material that is consistent with the standards for conspicuity promulgated by the National Highway Traffic Safety Administration if manufactured after December 31, 1993; and
  - (3) The semi-trailer shall be equipped with a rear under-ride guard of sufficient strength to prevent a motor vehicle from penetrating underneath the semi-trailer.

Federal Regulations require each trailer and semi-trailer with a gross vehicle weight rating of 10,001 pounds or more and manufactured after Jan 26, 1998, to meet more stringent standards. Rear under-ride guards may not be more than:

- 22" from the ground
- 4" from the side of the trailer
- 12" from the rear of the trailer

#### **4. MAXIMUM BUMPER HEIGHTS**

Class "E" trucks, with a manufacturer's rating or registered gross weight of more than 10,000 pounds, but not more than 18,000 pounds, may not be operated on any highway with a bumper that exceeds a clearance of 30 inches from the ground. If the truck is used for spraying agricultural crops, the maximum allowable height is 32 inches.

## **D. LOAD EXTENSION LIMITS - EXCEPTIONS**

The load on any vehicle or on the front of a combination of vehicles may not extend more than 3 feet beyond the front of the vehicle. The load on the rear of an automobile or boat transporter may not extend more than 4 feet beyond the rear of the vehicle.

"The load on any vehicle operated alone or the load on the rear vehicle of a combination of vehicles may not extend more than 6 feet beyond the rear of the bed or body of the vehicle." ("*The Maryland Vehicle Law, Title 24, §104 (c)*")

Vehicles carrying wooden prefabricated roof trusses, in an inverted position, are permitted a maximum rear extension of 10 feet. Combinations of vehicles carrying indivisible loads during daylight hours are allowed provided the load is not over 70 feet in length. Also exempt from the overhang restrictions are vehicles or combination of vehicles carrying piling, poles, mill logs, nursery stock or crew or racing shells.

The overall maximum length restrictions vary for particular vehicles. For additional questions regarding this matter, call the SHA Motor Carrier Division telephone numbers in Appendix C.

## **E. COVERING LOADS**

The beds on all vehicles transporting loose materials that include dirt, sand, gravel, wood chips, or other material that can blow, fall or spill from a vehicle as a result of movement or of exposure to air, wind, or weather, shall have its bed fully enclosed on all sides and covered with a canvas or other type of approved cover.

### Vehicles exempt from covered load law

- Class "K" Farm area
- Class "E" truck with manufacturer's rated capacity of 3/4 ton or less, and a maximum gross vehicle weight of 7,000 pounds or less
- Construction vehicle working within confines of a public works construction project site as outlined in the construction project's plans and specifications, provided the distance traveled does not exceed 1 mile or the distance specified in an extension granted
- Construction vehicle or mining equipment while crossing a highway between construction and mining sites
- All Class "G" trailers, provided no part of the load is higher than six inches below the top of any of the enclosures
- Within the Port of Baltimore for a distance not to exceed 1 mile, any vehicle carrying a load of loose material between a stockpile or storage facility and a vessel docked at the port

Dropping sand to improve traction or spreading water or other substance to clean or maintain a highway is allowed. **Agricultural products in their natural state or residue from processed vegetable products used as feed for animals that are being transported to a farm are also exempted.** The vehicle owner is responsible for removing spilled agricultural products from the highway.

For additional information, please call either the Maryland State Highway Administration's Motor Carrier Division or the Maryland State Police Commercial Vehicle Enforcement Division telephone numbers in Appendix C.

Flat bed or drop deck trailers are required to have a headboard or a "headache rack" installed on the back of the tractor.

## CHAPTER XIII

### OVERSIZE/OVERWEIGHT HAULING PERMITS

#### A. LEGAL WEIGHTS

Any vehicle with a gross maximum weight in excess of 73,000 pounds may travel only on State and federal numbered highways, except while making a delivery or pick-up, and then only when traveling by the shortest available legal route to or from the State or federal highway for the purpose of making the delivery or pick-up.

In Baltimore City, the shortest available legal route shall be only on designated truck routes.

#### B. OVERSIZE/OVERWEIGHT HAULING PERMITS

The State Highway Administration (SHA) may issue a permit allowing Oversized or Overweight vehicles carrying a load that cannot be reduced (i.e. item that cannot be disassembled, large equipment, containment vessels, etc.). Aspects regarding Maryland's Oversize/Overweight (OS/OW) Hauling Permits Program can be found in the "*Code of Maryland Regulations (COMAR), Title 11.*" Maximum weight registration and a minimum of five axles are required for Overweight Hauling Permits.

**Permit contact information:**

**Maryland State Highway Administration  
Hauling Permits Unit (HPU)**

**7491 Connelley Drive**

**Hanover, Maryland 21076**

**Telephone # 410-582-5727**

**Toll-free (within Maryland only)**

**1-800-543-4564**

**Email: [haulingpermits@sha.state.md.us](mailto:haulingpermits@sha.state.md.us)**

**OR**

**[MdMotorCarrier@sha.state.md.us](mailto:MdMotorCarrier@sha.state.md.us)**

**[Superloads@sha.state.md.us](mailto:Superloads@sha.state.md.us)**

PERMIT MOVES ALLOWED	NO PERMIT MOVES ALLOWED
<ul style="list-style-type: none"> <li>• As specified on permit</li> </ul>	<ul style="list-style-type: none"> <li>• Saturday after 12 noon</li> <li>• Sunday</li> <li>• State observed holidays</li> </ul>

SHA now accepts credit card/e-check for hauling permit payments. You no longer need to establish an account to get hauling permits online. Guest users may submit and pay for permits online. For more information visit:

<https://ahps.roads.maryland.gov>

**No permit movements are allowed on highways under the jurisdiction of the Maryland Transportation Authority (MDTA), after 12 noon on Friday until 9 a.m. Monday. Highways and structures under the authority of the MDTA include:**

- I-95 – John F. Kennedy Memorial Highway (portion of I-95 north of I-695 (Baltimore Beltway) to the Delaware State Line)
- I-95 – Fort McHenry Tunnel
- I-695 – Francis Scott Key Bridge
- I-895 – Baltimore Harbor Tunnel
- US 40 – Thomas J. Hatem Memorial Bridge (Susquehanna River Bridge)
- US 50/301 – William Preston Lane, Jr., Memorial Bridge (Chesapeake Bay Bridge)
- US 301 – Harry W. Nice Memorial Bridge (Potomac River Bridge)

For a listing of telephone numbers for facilities under the jurisdiction and control of the MDTA refer to Section E.

**For information on Baltimore City highways, call 410-396-7581.  
For information on Baltimore City Permits, call 443-984-2195**

**\*NOTE – EACH PERMIT THAT IS ISSUED IS UNIQUE IN THAT IT CONTAINS SPECIFIC INFORMATION AND REQUIREMENTS THAT THE PERMITEE MUST FOLLOW. FAILURE TO EITHER OBTAIN A PERMIT FOR A VEHICLE AND/OR LOAD THAT REQUIRES ONE, OR FAILURE TO ADHERE TO ANY CONDITIONS LISTED IN THE PERMIT MAY RESULT IN A \$1,020.00 FINE AND POSSIBLE CONFISCATION OF THE PERMIT.**

Overweight permits for vehicles carrying manifested international freight as the only load of the vehicle in a sealed seagoing container going to or from the Port of Baltimore for 24-hour travel on certain designated routes are available by contacting the SHA/HPU. Permits issued to 40' containers may not exceed **22,400** pounds gross maximum weight for a single axle, **44,000** pounds gross maximum for 2 consecutive axles, or **90,000** pounds gross maximum weight with the required axle spacing.

### **C. POSTED HIGHWAY DETOURS**

The SHA/HPU provides information on highway restrictions and detours. Refer to the telephone numbers in Appendix C. You may obtain more information on route restrictions by accessing the SHA Motor Carrier Division website at:

<http://www.roads.maryland.gov/OOTS/router1.pdf>

### **D. ESCORT POLICIES**

When carriers make application to the SHA/HPU for OS/OW vehicle use, escort by private personnel or Maryland State Police personnel is determined under COMAR, Title 11. If an escort is required, the permittee is responsible for this cost. For additional information regarding your responsibilities in these matters, please call the SHA/HPU telephone numbers in Appendix C.

## E. TOLL FACILITIES – TUNNELS – BRIDGE RESTRICTIONS

The permittee or user shall notify the MDTA Police (MDTAP) (specific locations listed below), or the MSP (I-95) and speak to the Duty Officer at least one hour before beginning movement of an OS/OW vehicle on or through the facility. The MDTAP or the Maryland State Police (MSP) on the JFK Highway (I-95) may be required to provide police escort for certain OS/OW Hauling Permit loads. The permittee is responsible for any additional fees that may be charged for required police escort.

- (1) I-895 - Baltimore Harbor Tunnel (MDTAP)  
**Telephone # 410-537-1230**
- (2) I-95 - Fort McHenry Tunnel (MDTAP)  
**Telephone # 410-537-1230**
- (3) US 301 - Harry W. Nice Memorial Bridge  
(Potomac River Bridge) (MDTAP)  
**Telephone # 301-259-4444**
- (4) US 50/301 - William Preston Lane, Jr.,  
Memorial Bridge (Bay Bridge) (MDTAP)  
**Telephone # 410-537-6601**  
or  
**410-757-1977**
- (5) I-695 - Francis Scott Key Bridge (MDTAP)  
**Telephone # 410-537-7600**
- (6) US 40 - Thomas J. Hatem Memorial Bridge (MDTAP)  
**Telephone # 410-537-1196**
- (7) I-95 - John F. Kennedy Memorial Highway (MSP)  
**Telephone # 410-537-1150**

The MDTA has comprehensive restrictions on the movement of Hazardous Materials (Haz-Mat) as defined in the "Hazardous Materials Regulations, Title 49, Code of Federal Regulations (CFR), Part 171.8," across highways under their jurisdiction.

**Haz-Mat loads such as flammable gases, liquids, explosives, and corrosives are not allowed in the Baltimore Harbor Tunnel (I-895), or the Fort McHenry Tunnel (I-95). For further information contact:**

Maryland Transportation Authority  
2301 South Clinton Street  
Baltimore, Maryland 21224  
Telephone # **410-537-1374**

**or**

**1-888-754-0185 (toll-free)**

MDTA website address:

<http://www.mdta.maryland.gov>

## CHAPTER XIV

### MAXIMUM ALLOWABLE VEHICLE & AXLE WEIGHTS

Maryland has adopted the Federal Bridge Formula (FBF) and Table regarding the maximum allowable vehicle axle/gross weights. The FBF was developed by the Federal Highway Administration (FHWA), to minimize damage to bridges and pavements caused by vehicles or combinations having too short a distance between the axles when carrying/hauling a heavy load across a bridge or structure. **Maryland does not allow loading tolerance errors on the Interstate Highways.**

#### A. BRIDGE FORMULA

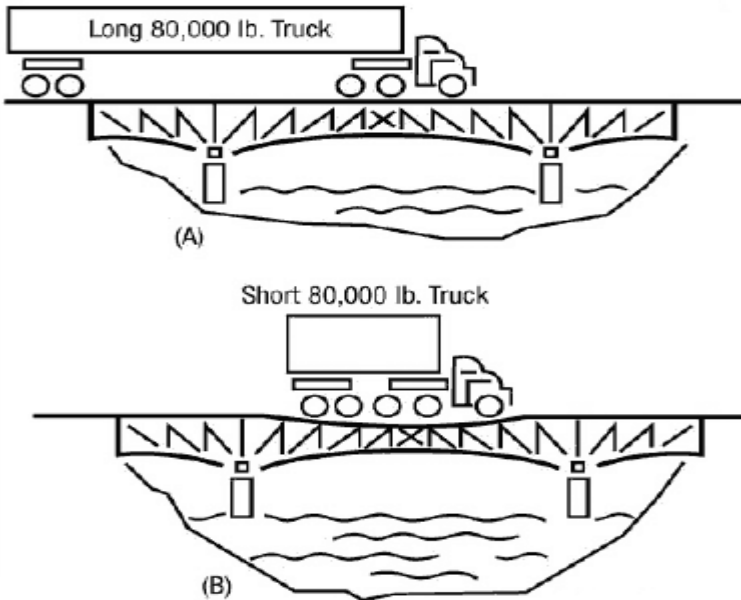

The above figures (A & B) represent what the Bridge Formula is designed to accomplish. A shorter wheelbase means you are not allowed to carry a heavier weight. This is because more stress is produced on a structure – such as a bridge when the weight of a vehicle is concentrated on a short wheel-base. A shorter wheel-based vehicle carrying a heavy load would cause substantial damage to the bridge.

The formula is as follows:

$$W = 500 \left[ \left( \frac{LN}{N-1} \right) + 12N + 36 \right]$$

"Where...

"**W**" = Overall gross weight on any group of 2 or more consecutive axles to the nearest 500 pounds,

"**L**" = Distance in feet measured horizontally between the vertical center lines of the extreme of any group of 2 or more consecutive axles, and

"**N**" = Number of axles in a group under consideration, except that 2 consecutive sets of tandem axles may carry a gross load of 34,000 pounds each providing the overall distance between the first and last axles of such consecutive sets of tandem axles is 36 feet or more; provided that such overall gross weight may not exceed 80,000 pounds, including any enforcement or statutory tolerances." (*The Maryland Vehicle Law, Title 24, §109 (b)*)

**Refer to the next page for the Bridge Table.**

# BRIDGE TABLE

## DISTANCE IN FEET BETWEEN THE EXTREMES OF ANY GROUP OF 2 OR MORE CONSECUTIVE AXLES

	2 axles	3 axles	4 axles	5 axles	6 axles	7 axles
4	34,000					
5	34,000					
6	34,000					
7	34,000					
8	34,000	34,000				
and less						
More than						
8	38,000	42,000				
9	39,000	42,500				
10	40,000	43,500				
11		44,000				
12		45,000	50,000			
13		45,500	50,500			
14		46,500	51,500			
15		47,000	52,000			
16		48,000	52,500	58,000		
17		48,500	53,500	58,500		
18		49,500	54,000	59,000		
19		50,000	54,500	60,000		
20		51,000	55,500	60,500	66,000	
21		51,500	56,000	61,000	66,500	
22		52,500	56,500	61,500	67,000	
23		53,000	57,500	62,500	68,000	
24		54,000	58,000	63,000	68,500	74,000
25		54,500	58,500	63,500	69,000	74,500
26		55,500	59,500	64,000	69,500	75,000
27		56,000	60,000	65,000	70,000	75,500
28		57,000	60,500	65,500	71,000	76,500
29		57,500	61,500	66,000	71,500	77,000
30		58,500	62,000	66,500	72,000	77,500
31		59,000	62,500	67,500	72,500	78,000
32		60,000	63,500	68,000	73,000	78,500
33			64,000	68,500	74,000	79,000
34			64,500	69,000	74,500	80,000
35			65,500	70,000	75,000	
36			66,000	70,500	75,500	
37			66,500	71,000	76,000	
38			67,500	72,000	77,000	
39			68,000	72,500	77,500	
40			68,500	73,000	78,000	
41			69,500	73,500	78,500	
42			70,000	74,000	79,000	
43			70,500	75,000	80,000	
44			71,500	75,500		
45			72,000	76,000		
46			72,500	76,500		
47			73,500	77,500		
48			74,000	78,000		
49			74,500	78,500		
50			75,500	79,000		
51			76,000	80,000		
52			76,500			
53			77,500			
54			78,000			
55			78,500			
56			79,500			
57			80,000			

\*Note exception to the Bridge Formula in Section C

## B. EXAMPLES – HOW TO DETERMINE GROSS VEHICLE WEIGHT AND MULTIPLE AXLE WEIGHTS USING THE BRIDGE FORMULA

The vehicle with weights and axle dimensions as shown in Figure 1, illustrates a Bridge Formula check.

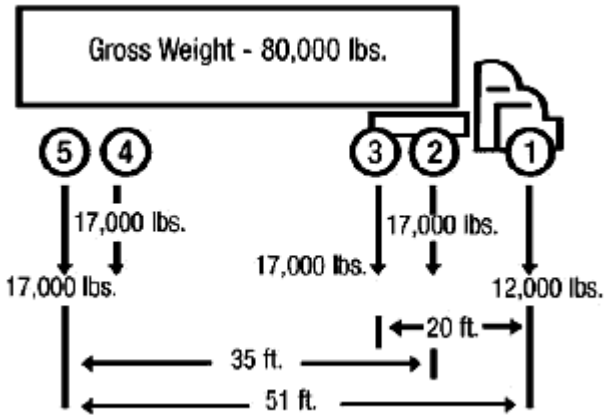

(Figure 1)

Before checking axle 1 through 3 spacing, check to see that single, tandem and gross weights are satisfied. The single axle Number 1 should not exceed 20,000 pounds, tandem axles should not exceed 34,000 pounds, and the gross weight should not exceed 80,000 pounds (refer to the Bridge Table to assure the vehicle has enough axles and spacing that allows the maximum gross vehicle weight (GVW) of 80,000 pounds).

In Figure 1, the 12,000 pound weight for the steering axle is given as an example. Maryland allows a maximum gross axle weight limit of 20,000 pounds on a single axle under the following circumstances:

1. The vehicle is registered for more than 73,000 pounds; and
2. The sum of the rated load capacities for each tire on the axle do not exceed the stated capacity (weight); or
3. The sum of the rated load capacities indicated by the manufacturer as to each tire on the axle with which the vehicle was originally equipped is not exceeded.

These requirements are satisfied, so the next thing you need to check is shown in Figure 2:

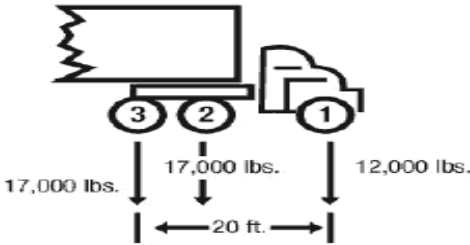

(Figure 2)

### Check of axles 1 through 3

Actual weight = 12,000 + 17,000 + 17,000 = 46,000 pounds.

N = 3 axles

L = 20 feet

$$W = 500 \left[ \frac{LN}{N-1} + 12N + 36 \right]$$

$$W = 500 \left[ \frac{(20 \times 3)}{(3 - 1)} + (12 \times 3) + 36 \right] = 51,000 \text{ lbs.}$$

*W* maximum = 51,500 pounds which is more than the actual weight of 46,000 pounds so the Bridge Formula requirement is satisfied.

In the previous example, if axles 2 and 3 are 17,000 pounds each (34,000 pounds total), the steering axle could be 17,500 pounds and the truck would be legal if the axle distances remain the same and the **tire load rating on the sidewall indicates this weight may be carried**. If the tire rating (both front tires) indicates the rating for each is 7,000 each, then the front axle would only be allowed a maximum gross weight of 14,000 pounds regardless of the axle spacing (Bridge Formula).

Taking the same number (51,500 pounds gross weight) from the previous example obtained from Bridge Table as shown by reading down the left side to **L=21** and across to the right where **N=3**, you can determine the overall gross weight limits (including axle weights), by following the below listed example.

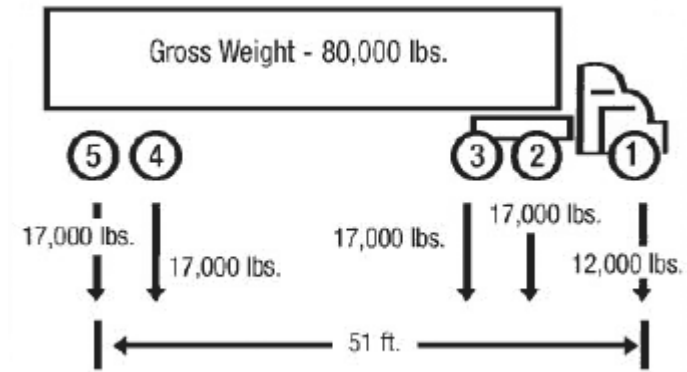

(Figure 3)

**Now check axles 1 through 5 to determine the maximum allowable gross vehicle weight (GVW). (Refer to Figure 3 above)**

$$W \text{ (actual)} = 12,000 + 17,000 + 17,000 + 17,000 + 17,000 = 80,000 \text{ pounds.}$$

**W** maximum, from the Bridge Table for **L** of 51 feet and **N** of 5 = 80,000 pounds. (Includes 1,000 pound tolerance\*) The measurement of 51' which is made from the center of the hub on the steering axle of the truck, to the center of the hub on the last axle of the trailer is commonly referred to as the "exterior (or outer) bridge." Therefore, this axle spacing is satisfactory.

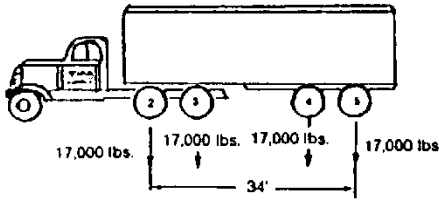

Figure 4

Next check axles 2 through 5 (Shown in Figure 4 above).

$$W \text{ (actual)} = 17,000 + 17,000 + 17,000 + 17,000 = 68,000 \text{ pounds.}$$

$W$  maximum, from the Bridge Table for " $L$ " of 35 feet and " $N$ " of 4 = 64,500 pounds. The distance measurement (shown in Figure 4), is taken from the center of axle #2 to the center of axle #5. This measurement is commonly referred to as the "interior (or inner) bridge."

The measurement of 34' reveals an interior bridge weight violation because the actual weight exceeds the maximum allowed weight for the given axle spacing. To correct the situation, some of the load must be removed from the truck or the axle spacing (34-foot dimension) increased.

### Bridge Formula Example for Three Consecutive Axles

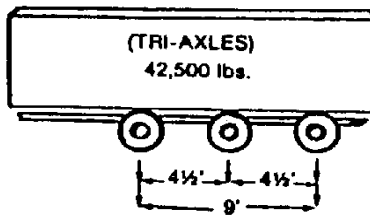

Figure 5

If the distance in Figure 5, measured from the center of the first axle to the center of the last axle of the semi-trailer is 9' then a maximum allowable tridem axle (3 axles) weight of 42,500 pounds would be allowed.

### C. EXCEPTION TO THE BRIDGE FORMULA

There is an exception to the Bridge Formula . That is, two or more consecutive sets of tandem axles spaced more than 40 inches apart, but not more than 96 inches apart may carry a gross load of 34,000 pounds each, providing the overall distance between the first and last axles of such consecutive sets of tandem axles is 36 feet or more. This is the exception stated in the Bridge Table which refers to paragraph (b) of the "Transportation Article," Title 24, §109.

For example, a 5-axle truck-tractor-semi-trailer is allowed a maximum tandem axle weight of 34,000 pounds on the tandem of the tractor (axles 2 and 3) and 34,000 pounds on the tandem of the trailer (axles 4 and 5), provided there is an overall spacing of 36 feet or more between axles 2 and 5 for a weight of 68,000 pounds for these two sets of tandems.

A spacing of 36 feet or more for axles 2 through 5, is satisfactory for an actual weight of 68,000 pounds for the two sets of tandem axles even though the Bridge Table shows an allowed weight of 66,000 to 67,000 pounds for spacing of 36 feet to 38 feet. Again, note the exception shown in the Bridge Table.

**Remember, the exception granted under law is for two or more consecutive sets of tandem axles spaced more than 40 inches apart, but not more than 96 inches apart providing the overall distance between the first and last axles of such consecutive sets of tandem axles is 36 feet or more. For example, if the distance between axles 4 and 5 is more than 96" (8'), then the tandem would not qualify as part of the 2 consecutive sets of tandems and would be considered one tandem by itself. Under this circumstance, the Bridge Formula weight of 66,500 pounds would apply if the distance between axles 2 through 5 was 37 feet, and it would not fall within the exemption.**

Should you have any questions regarding the measurements for axles, weight laws, etc., please call the SHA Motor Carrier Division telephone numbers in Appendix C.

For an Overweight Hauling Permit for international, sealed sea-going containers (containerized cargo), refer to Chapter XIII (Oversize/Overweight Hauling Permits).

#### D. GROSS WEIGHT LIMITATIONS BASED ON THE NUMBER OF AXLES

The Gross Vehicle Weight (GVW) of any vehicle or combination of vehicles as shown below may not be exceeded.

NUMBER OF AXLES	GROSS VEHICLE WEIGHT OR GROSS COMBINATION WEIGHT (IN POUNDS)
Three or less	55,000
Four	66,000
Five or more	80,000

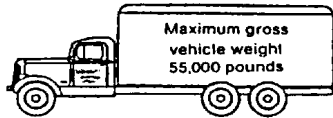

3-axle vehicle

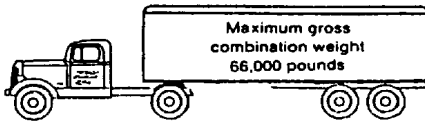

4-axle combination

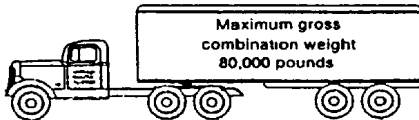

5-axle combination

The allowable weights for the vehicles or vehicle combinations listed above will be determined based on the vehicle meeting the Bridge Formula.

## E. WEIGHT ENFORCEMENT PROGRAM

The Maryland State Police, Commercial Vehicle Enforcement Division (MSP/CVED), and the Maryland Transportation Authority Police, Commercial Vehicle Safety Unit (MDTAP/CVSU), conduct truck size and weight enforcement operations at Truck Weigh and Inspection Stations (TWIS) throughout Maryland. The MDTAP/CVSU normally conducts operations on toll facilities only. Both departments also conduct size and weight enforcement operations through the use of roving patrols equipped with portable scales.

Baltimore and Anne Arundel County Police Departments likewise conduct roving operations for weight enforcement utilizing portable scales. Other allied police agencies in Maryland conduct roadside motor carrier safety inspections on vehicles and enforce safety and size laws.

**The fine for refusing to submit to weighing and measurement is \$1,000.00, plus any court costs. A loading error or tolerance of 1,000 pounds is allowed, but not given on Interstate highways.**

Except as otherwise provided in "*The Maryland Vehicle Law, Title 24, § 111.1,*" a vehicle found to exceed any allowable weight limit by 5,000 pounds or more may not be moved until the excess weight is unloaded.

## CHAPTER XV

### MOVEMENT OF HAZARDOUS MATERIALS (HAZ-MAT)

#### A. GENERAL INFORMATION

Maryland has adopted the "*Federal Hazardous Material Regulations, Title 49, Code of Federal Regulations (CFR), Parts 107 through 180,*" and all amendments to them.

Carriers with general questions regarding the routine handling, shipment, routing and transport of Haz-Mat, or the applicability of the regulations can write the Maryland Department of the Environment (MDE) at Montgomery Business Park, 1800 Washington Blvd. STE 645, Baltimore, Maryland 21230, or call them at **410-537-3975**. For additional information you can access the MDE website address at:

<http://www.mde.state.md.us>

**Motor Carriers hauling hazardous waste must be certified for pickup and delivery in Maryland. For permit information call 410-537-3975.**

#### B. SCRAP TIRE HAULERS

Individuals who pick-up, or deliver scrap tires in the State of Maryland are required to obtain a Scrap Tire Hauler License. For license information contact the MDE, Office of Waste Minimization and Recycling at **410-537-3315**.

#### C. MOTOR FUEL TRANSPORTERS

Any person transporting motor fuel in interstate or intrastate commerce must register as a Petroleum Transporter. For additional information call the Maryland Comptroller's Office, Motor-fuel, Alcohol and Tobacco Tax Unit telephone numbers Appendix C.

## D. BULK PETROLEUM TRANSPORTERS

Companies that have trucks with a storage capacity of 500 gallons or more of bulk petroleum products must obtain a permit from MDE's Oil Control Program. Drivers must comply with the vehicle attendance requirements when loading and unloading.

## E. HAZ-MAT RELEASE REPORTS

Anytime Haz-Mat is accidentally released it presents a danger to others. See the chart shown below for guidance in these matters.

Who do I call?	What do I need to provide?
<ul style="list-style-type: none"><li>• Call the Maryland Department of the Environment (MDE) Hazardous Materials Spill and Oil Response (24 hours) at:  1-866-633-4686</li></ul>	<ul style="list-style-type: none"><li>• Location of the incident</li><li>• Date and time</li><li>• Presence of fire, explosion, or impending danger to life or property</li><li>• Identification of the materials released (e.g., name, ID number, label, location, and characteristics)</li><li>• The extent of any injuries</li></ul> <p>If an oil spill is involved, you are required to call MDE within 2 hours of the release/spill, and file a follow-up report to MDE within 10 days of the spill/release</p>

Carriers involved in a Haz-Mat release, must submit a report to the US Department of Transportation, according to, "Code of Federal Regulations (CFR), Title 49, Part 171.15." and "CFR, Title 49, Part 171.16." within 30 days of the date of the incident.

## CHAPTER XVI

### ENVIRONMENTAL ENFORCEMENT PROGRAMS

#### A. DIESEL VEHICLE EMISSIONS CONTROL PROGRAM (DVECP)

Under the DVECP, vehicles powered by a diesel engine (compression ignition engine) with a gross vehicle weight rating (GVWR), or gross combination weight rating (GCWR) over 10,000 pounds (i.e., trucks, buses and other vehicles) are subject to testing of their engine exhausts to determine if the vehicle exceeds smoke emissions levels.

Both the Maryland State Police Commercial Vehicle Enforcement Division (MSP/CVED), and Maryland Transportation Authority Police Commercial Vehicle Safety Unit (MDTAP/CVSU), conduct initial and re-testing on the above listed vehicles, utilizing smoke opacity meters to determine if they meet the emissions standards adopted by the State. Diesel emissions inspectors are either law enforcement officers, or civilian inspectors working in concert with enforcement personnel.

Emissions inspectors follow procedures specified in the Society of Automotive Engineers (SAE), "J1667 Snap-Acceleration Test Procedure for Heavy-Duty Diesel Powered Vehicles." which has been adopted for use by the State of Maryland.

The smoke opacity testing cut-points (allowable smoke density percentages) for Maryland are:

- For vehicles 1991 and newer: 40% opacity
- For vehicles 1990 to 1974: 55% opacity
- For vehicles 1973 and older: 70% opacity

Vehicles are subject to an emissions test:

- a. When the vehicle is required to submit to weighing and measurement, or
- b. As part of a motor carrier safety inspection, or
- c. At any location or time when a police officer has reasonable cause to believe the vehicle is violating emissions standards.

Enforcement action taken for vehicles failing an emissions test consists of the following:

**(1) Maryland registered vehicles**

- a. If the vehicle fails an emissions test, a Safety Equipment Repair Order (SERO) is issued. The owner of the vehicle has 10 days to have the vehicle repaired and re-tested and within 30 days from the issuance of the SERO, the owner must mail in the last copy of the SERO to the Maryland State Police Automotive Safety Enforcement Division (MSP/ASED).
- b. If the owner fails to comply with the SERO, the MVA will suspend the vehicle registration. The penalty for driving with suspended registration is a \$1,000.00 fine.

**(2) Foreign registered vehicles**

- a. After emissions testing, the vehicle driver is provided a copy of a Driver/Vehicle Inspection Report (DVIR). The vehicle owner has 15 days to certify the vehicle has been repaired, and has a total of 30 days to mail a copy of the DVIR to the MSP/CVED.

- b. If the owner fails to comply with the 30-day limit, MSP/CVED will notify the FMCSA. The notice may trigger an FMCSA audit of the violator. The penalty for failing to comply with the DVECP carries a fine of \$1,000.00.

To enhance the DVECP, Certified Diesel Emissions Re-Testers, (CDER's) who are third party re-testers participate in the program. CDER's are personnel who currently work at an authorized State Inspection Station (SIS), or other business (i.e., engine repair facility and/or engine rebuilding facility). CDER's are certified by the Maryland Department of the Environment to perform re-tests.

If you have questions regarding this program, please call the MSP/CVED, MDTAP or MDE telephone numbers Appendix C.

## **B. NOISE ABATEMENT PROGRAM**

Maryland's Noise Abatement Program (NAP) specifies a person may not operate or permit to be driven on a highway of this State any motor vehicle, or combination of vehicles at any time or at any speed, under any conditions of grade, load, acceleration, or deceleration in a manner which would exceed the sound level limits as specified in the "Code of Maryland Regulations" (COMAR).

The MSP/CVED has trained inspectors equipped with sound measurement devices to enforce this program. Testing for vehicles having a GVWR/GCWR in excess of 10,000 pounds is performed in accordance with the SAE Standard, "J986b Exterior Sound Level for Heavy Trucks and Buses."

Persons who have questions regarding the noise limits for vehicles having a GVWR, and GCWR in excess of 10,000 pounds as well as testing procedures should call the MSP/CVED at the telephone number in Appendix C.

## CHAPTER XVII

### PORT OF BALTIMORE

#### ACCESS TO THE PORT

Seagirt and Dundalk, the Port's two largest container facilities, are easily reached via the Keith Avenue exit off I-95, immediately north of the Fort McHenry Tunnel toll plaza. After exiting I-95, travel one mile east on Keith Avenue to Broening Highway, and south less than one mile to Seagirt. The Dundalk Marine Terminal is just beyond Seagirt on Broening Highway.

#### For entry into the Port of Baltimore:

**Carriers:** Must be registered through the Emodal System. For more information visit their website at:

<http://www.emodal.com>

For additional information call: 1-949-474-3140

or

1-206-382-4491

**Drivers:** To enter the Port must have a current Transportation Worker Identification Credential (TWIC). For more information visit the following website at:

<http://homeport.uscg.mil/twic>

Or

<http://www.tsa.gov/twic>

If you do not have a TWIC you will need to be escorted into the Port terminal. For addition information, visit:

<http://www.mpa.maryland.gov/content/port-twic-regulations.php#Escort>

## CHAPTER XVIII

### TRAFFIC CRASH REPORTING

#### GENERAL REQUIREMENTS

Maryland law requires the driver of a vehicle involved in a crash to do several things. **If you are involved in a crash you are required to stop immediately, return to the scene and remain there until the following requirements have been fulfilled:**

- 1) Give reasonable assistance to any person injured.
- 2) Give your name, address, the registration number of the vehicle they are driving.
- 3) On request show your driver's license, if it is available, to any person injured in the crash, the driver, occupant, or person attending any vehicle or property damaged in the crash.
- 4) Provide the owner with your name and address, and if you are driving someone else's vehicle, the name and address of owner of the vehicle as well as the registration number for the vehicle.
- 5) In the case of unattended vehicles or property attempt to locate the owner.
- 6) If the driver, owner, or person in charge of the damaged vehicle or other property cannot be located, you are required to leave in a conspicuous, secure place in or on the damaged vehicle or other property a written notice containing the same information.
- 7) Give the name and address of your insurance carrier or other security provider, along with a policy or other identifying number of the liability insurance, if available, and name and address of the local agent or local office of the your insurance carrier, if available.
- 8) If your vehicle strikes and injures a domestic animal, the driver of the motor vehicle shall immediately notify the appropriate State or local police of the crash.

Motor carriers are no longer required to submit accident (crash) reports to the Federal Motor Carrier Safety Administration (FMCSA), and notify the agency of fatal accidents. Instead, the FMCSA currently depends on reports from the enforcement agencies that investigate the crash.

The motor carrier is required to maintain for a period of one year after an accident occurs, an accident register containing at least the following information:

- a. A list of accidents containing the date, city or town and state in which the crash occurred, driver name, number of injuries, number of fatalities and whether hazardous materials (other than fuel spilled from the fuel tanks of the vehicles involved in the crash) were released.
- b. Copies of all accident reports required by State or other governmental entities or insurers.

**“FMCSR,” defines an accident (crash) as:**

- **A fatality, or**
- **Bodily injury to a person who immediately receives medical treatment away from the scene of the accident**
- **One or more motor vehicles incurring disabling damage as a result of the accident requiring the vehicle be towed or transported from the scene by a tow truck or other vehicle**

## CHAPTER XIX

### MARYLAND MOTOR CARRIER SAFETY PROGRAM (MMCSP)

#### A. PURPOSE OF PROGRAM

The Maryland Motor Carrier Safety Program (MMCSP) in the State has evolved since its inception in 1985. The number of safety inspections conducted on buses, trucks, drivers and their cargos per year has increased from 4,978 in 1986, to 98,582 in 2010.

#### Goals of the MMCSP

- Reduce traffic crashes involving CMV's
- Reduce deaths, injuries and property loss resulting from them
- Reduce the risk involving the transportation of Haz-Mat

Enforcement agencies participating in the MMCSP conduct safety inspections on commercial motor vehicles (CMV's) and drivers to assure they are in compliance with the "Federal Motor Carrier Safety Regulations" (FMCSR). Vehicles can be placed Out-Of-Service (OOS) for vehicle defects based on the Commercial Vehicle Safety Alliance (CVSA) OOS criteria. An OOS sticker will be affixed to vehicle units placed OOS. Drivers who exceed their allowable hours of service, or violate the regulations pertaining to drug and/or alcohol usage, or who are not qualified to drive a CMV, likewise will be placed OOS.

Inspectors may place a CVSA decal on vehicles that pass a Level I safety equipment inspection without serious defect. Maryland inspectors may waive the inspection of vehicles displaying current CVSA inspection decals issued by Maryland, or CVSA member jurisdictions. Finally, a Maryland Driver/Vehicle Inspection Report will be completed for each driver and/or vehicle inspection. Copies of these inspections are provided to the Federal Motor Carrier Safety Administration (FMCSA).

## B. PREVENTIVE MAINTENANCE (PM) PROGRAM

Owners of certain Maryland registered vehicles are required to have them inspected, maintained, and repaired at least every 25,000 miles, or every 12 months, whichever occurs first. Owners also are required to keep maintenance records on their vehicles.

### Purpose of the PM Program

- Ensure Maryland registered vehicles are maintained in safe operating condition
- Ensure owners follow minimum levels of inspection, maintenance and repairs for certain vehicles
- Prevent crashes
- Promote highway safety

The PM program covers the following Maryland registered vehicles:

1. A Class "E" single unit truck with a rated, registered or operating gross vehicle weight (GVW) of over 10,000 pounds.
2. A Class "E" truck with a registered gross combination weight (GCW) greater than 10,000 pounds when operated in combination with a freight trailer or semi-trailer.
3. A Class "F" truck tractor.
4. A Class "G" freight trailer or freight semi-trailer.
5. A Class "P" passenger bus.
6. A Class "M" multipurpose vehicle which has a seating capacity for 16 or more passengers, including the driver, or was previously registered as a Class "H" school vehicle, or a Class "P" passenger bus and which is used to primarily to transport passengers.

7. Dump truck - used to haul feed and other loose materials in bulk and designed to self-unload by gravity or mechanical means, and registered under "*The Maryland Vehicle Law, Title 13, §919.*"\*

**\*NOTE:** Dump trucks in operation for at least 18 years from the vehicle's model year or first registration date, whichever is later, must be inspected every 12,500 miles or 6 months, whichever occurs first. The vehicle owner has the responsibility of assuring the vehicle meets or exceeds the standards contained in the rules and regulations. It is important to note that this law does not change any other law or regulation affecting a vehicle or its components. **All vehicles using Maryland highways must be in a safe operating condition at all times.**

8. Any vehicle or combination of vehicles owned by the State of Maryland or any political subdivision in the state which are:
  - a. Single unit trucks with a GVW greater than 10,000 pounds.
  - b. Single unit trucks with a GCW greater than 10,000 pounds when operated in combination with a freight trailer or semi-trailer.
  - c. Truck tractors.
  - d. Freight trailer or semi-trailer, and
  - e. Buses designed and used to carry more than 10 people and not regulated by "*The Maryland Vehicle Law, Title 25, §110.*"

All Maryland-registered vehicles listed on pages 105 and 106, are included in Maryland's PM Program. The vehicle's owner must provide certification when registering a new vehicle that they are in compliance with the Program. Violation of the PM Program can subject the owner to fines up to \$520.00, as well as possible suspension of the vehicle registration by MVA.

**Where can I get a PM Handbook?**

**Office of the Secretary of State  
Division of State Documents  
16 Francis Street  
Jeffrey Building  
Annapolis, Maryland 21401-1924**

**The Division of State Documents charges a nominal fee for the Handbook. For information call them at (410) 974-2486 or toll-free (within Maryland only) at 1-800-633-9657, or visit their website at:**

**<http://www.dsd.state.md.us>**

The FMCSA has certified that the Maryland PM Program meets the requirements of the federal annual inspection process as contained in the "*FMCSR, Part 396.17.*"

## CHAPTER XX

### FEDERAL MOTOR CARRIER SAFETY REGULATIONS (FMCSR)

#### A. GENERAL ISSUES

Maryland enforces the following "FMCSR, Title 49, Code of Federal Regulations," (CFR) which was adopted into the "Code of Maryland Regulations (COMAR), Title 11":

- Part 40
- Parts 107 through 180, dealing with the transportation of Haz-Mat
- Part 382, dealing with drug and alcohol testing and the carrier maintaining drug and alcohol testing records
- Part 383, dealing with Commercial Driver's Licenses
- Parts 390 through 393, and 395 through 399.

"The Maryland Vehicle Law, Title 25, §111," governs Maryland's enforcement of the FMCSR, regarding commercial motor vehicles (CMV). Noncompliance can result in a maximum fine of \$1020.00.

The regulations apply to the following vehicles:

- Trucks
- Truck tractors
- Buses
- Trailers, semi-trailers, pole trailers
- Converter dollies
- Combinations of vehicles if the gross vehicle weight rating (GVWR) exceeds 10,000 pounds
- All interstate and intrastate motor carriers of property or passengers

For further information, call the SHA Motor Carrier Division or the Federal Motor Carrier Safety Administration (FMCSA) number in Appendix C.

For vehicles transporting Haz-Mat that require the vehicle to be marked or placarded in accordance with the "CFR, Parts 107 through 180," or for vehicles designed to transport 16 or more occupants, drivers must comply with all of the FMCSR, including medical examination and certification requirements contained in Part 391, regardless of vehicle size/weight.

Copies of the FMCSR are available for sale by the Maryland Motor Truck Association (Refer to Appendix C) and the US Government Printing Office.

The following summarization of the FMCSR adopted by Maryland applies to motor carriers, officers, agents, representatives, supervisors, and employees responsible for the management, maintenance, operation, or driving of motor vehicles.

## **B. PART 391 - QUALIFICATIONS OF DRIVERS**

### **Interstate Drivers**

To drive a CMV interstate you must:

- Be at least 21 years old, and
- Be able to read and speak the English language sufficiently to converse with the general public and to understand highway traffic signs and signals, and to respond to official inquiries, and
- Have a current medical card, and
- Possess a valid license from only one state.

The medical examination and certification requirements contained in the "FMCSR, Part 391.41 (a), 391.43 and 391.45," apply to both interstate and intrastate drivers who operate a CMV, or CMV combination with a gross vehicle weight rating (GVWR), or gross combination weight rating (GVWR) of 10,001 pounds, or more.

**Interstate drivers who are not medically qualified to operate a CMV and who wish to drive are required to obtain a waiver from the FMCSA. For questions regarding medical waivers, call the FMCSA at 443-703-2240.**

A drug and alcohol testing program for interstate and intrastate drivers with a CDL operating a CMV requiring a Commercial Driver's License (CDL) is in force in Maryland as contained in the FMCSR.

### **Intrastate Drivers**

**Intrastate drivers of CMV's with a GVWR, or GCWR of 10,001 pounds or more are required to have a current medical examiner's certificate, or copy in their possession certifying they are qualified to drive them.**

An intrastate driver who does not meet the physical qualifications under the FMCSR, Part 391.41 (b)(1-11), may still drive a CMV if:

1. Qualified to drive a CMV, and was driving a CMV before October 1, 2003; and
2. Not transporting Haz-Mat; and
3. Not operating a vehicle carrying 16 or more passengers including the driver; and
4. Having a disqualifying physical condition that does not get worse.

**Drivers must continue to carry a current medical card and be retested every two years.** For more information, call the SHA Motor Carrier Division numbers in Appendix C.

C. PART 392 - DRIVING OF COMMERCIAL MOTOR VEHICLES (CMV'S)

Carriers shall not:	Drivers shall not:
<ul style="list-style-type: none"><li>• Allow the operation of a CMV while the driver's ability or alertness is impaired through:<ol style="list-style-type: none"><li>1. Fatigue, or</li><li>2. Illness, or</li><li>3. Any other cause.</li></ol></li></ul>	<ul style="list-style-type: none"><li>• Operate a CMV while their ability or alertness is impaired through:<ol style="list-style-type: none"><li>1. Fatigue, or</li><li>2. Illness, or</li><li>3. Any other cause.</li></ol></li><li>• While on-duty or driving, possess, consume, be under the influence of or use:<ol style="list-style-type: none"><li>1. An intoxicating beverage, or</li><li>2. Prohibited drugs.</li></ol></li><li>• Consume an intoxicating beverage within 4 hours before going on duty or operating, or having physical control of a CMV.</li></ul>

Drivers violating these rules are subject to be placed Out-Of-Service (OOS) for 24 hours, and must report such declaration to their employer within 24 hours and to the licensing state within 30 days.

Before driving, drivers shall be satisfied that the motor vehicle is in safe operating condition. At a minimum the driver must check the following parts and accessories:

1. Brakes - service, trailer connections, parking (hand).
2. Steering mechanism.
3. Lighting devices and reflectors.
4. Tires.
5. Horn.

6. Windshield wiper or wipers.
7. Rear vision mirror or mirrors, and
8. Coupling devices.

The following emergency equipment shall be carried on all vehicles in the proper place, and shall be ready for use by the driver:

- Fire extinguisher – properly filled, readily accessible, securely mounted, and
- Spare fuses or overload protection device,
- Three emergency, bi-directional, reflective triangles (fuses, liquid burning flares, or red electric lanterns may be used instead of triangles). **However, flame producing devices are prohibited for certain types of Haz-Mat transport.**

**D. PART 393 - PARTS AND ACCESSORIES NECESSARY FOR SAFE OPERATION**

Part 393, details the requirements for lighting devices, reflectors, electrical equipment, brakes, glazing/window construction, fuel systems, coupling devices and towing methods, emergency equipment, protection against shifting or falling cargo, load securement utilizing certain equipment, and other miscellaneous parts and accessories (e.g., tires, mirrors, horn, rear end protection, projecting loads, seat belt assemblies, etc.). No vehicle shall be operated unless it is equipped with these devices. All parts and accessories shall at all times be in safe and proper operating condition.

## E. PART 395 - HOURS OF SERVICE FOR DRIVERS

The Hours of Service are currently undergoing revision, for additional information on the Hours of Service for Drivers go to the FMCSA website at:

<http://www.fmcsa.dot.gov>

At the website, click on " Rules and Regulations," then click on Part 395.

### CDL Drivers of Property-Carrying Vehicles - Interstate

Drivers shall:

- Drive no more than 11 hours;
- Not drive after their 14<sup>th</sup> consecutive hour after coming on duty;
- Have 10 consecutive hours off duty between driving time, or sleeper berth split of at least 8 hours and 2 hours;
- Not exceed 60 hours on duty in 7 consecutive days if the motor carrier does not operate vehicles everyday of the week, or exceed 70 hours one duty in 8 consecutive days if the motor carrier operates vehicles everyday of the week.

Drivers are required to maintain a record of duty status (Logbook) regarding their Hours of Service.

The Record of Duty Status (Log Book) must:

1. Be maintained for each 24-hour period, in duplicate, current to the last change of duty status; and
2. Be carried by the driver and contain the log for the previous 7 days; and
3. Be retained by the carrier for six months.

Refer to the FMCSR, Part 395.3 and Part 395. 8.

## Short Haul Provisions - Driver of Property-Carrying Vehicles - Interstate

There are two short haul provisions in the FMCSR, covering the Hours of Service for drivers who operate interstate. The first deals with CDL drivers who operate within 100 air-miles, and the other deals with Non-CDL drivers who operate within 150 air-miles. For additional information, you can either review this information on-line at the FMCSA website at: <http://www.fmcsa.dot.gov> or call the SHA/MCD numbers in Appendix C.

Refer to the FMCSR, Part 395.1.

### Drivers of Property-Carrying CMV's Not Requiring a CDL - Interstate

Drivers of property carrying vehicles that **DO NOT** require a CDL and operate within a 150 air-mile radius of their work location are not required to keep a logbook, and can have up to two days a week where their on duty time is extended to 16 consecutive hours.

These drivers shall:

- Not drive more than 11 hours;
- Not drive after their 14<sup>th</sup> consecutive hour after coming on duty;
- Have 10 consecutive hours off duty between driving time;
- Not drive after the 16<sup>th</sup> hour after coming on duty on 2 days of any period of 7 consecutive days;
- Not exceed 60 hours on duty in 7 consecutive days if the motor carrier does not operate vehicles every day of the week, or exceed 70 hours in 8 consecutive days if the motor carrier operates motor vehicles every day of the week.

The motor carrier that employs the driver shall maintain and retain certain records for these types of drivers. **Refer to the FMCSR, Part 395.1**.

## Drivers of Passenger-Carrying Vehicles - Interstate

Drivers of passenger carrying vehicles shall not drive:

- More than 10 hours following 8 consecutive hours off duty.
- For any period after having been on duty 15 hours following 8 consecutive hours off duty.
- After having been on duty 60 hours in any period of 7 consecutive days if the employing motor carrier does not operate CMV's every day of the week, or 70 hours in any period of 8 consecutive days if the employing motor carrier operates CMV's every day of the week.

Refer to the FMCSR, Part 395.5.

## Intrastate Drivers of Property-Carrying or Passenger-Carrying Vehicles

Drivers of property-carrying vehicles and passenger-carrying vehicles shall not:

- Drive more than 12 hours following 8 consecutive hours off duty.
- Drive after having been on duty more than 16 hours.
- Drive after being on duty more than 70 hours in a period of 7 consecutive days if the employing motor carrier does not operate vehicles every day of the week.
- Drive after being on duty more than 80 hours in a period of 8 consecutive days if the employing motor carrier operates vehicles every day of the week.

**To be exempt from keeping a log of their hours of service, drivers are required to meet all of the conditions listed above, and stay within a 150 air-mile radius and return to their normal work reporting location. Refer to "The Maryland Vehicle Law, Title 25, §111."**

## F. PART 396 - INSPECTION, REPAIR, AND MAINTENANCE

Motor carriers shall systematically inspect, repair and maintain all vehicles subject to their control. Specific certification of the PM program is covered in Chapter XIX, Section B, and goes beyond the FMCSR summarized here.

In addition to vehicle equipment specified in the FMCSR, Part 393, other parts which may affect the safety of a vehicle, including frame/frame assemblies, suspension systems, axle and attaching parts, wheels and rims, and steering system, must be maintained in a safe and proper operating condition.

The following records are required (except for vehicles controlled for less than 30 days) to be maintained. The records shall be retained by the motor carrier where the vehicle is either housed or maintained for a period of one year, and for six months after the vehicle leaves the carrier's control. If the vehicle is Maryland registered, the following files must be retained for two years:

1. Vehicle identification (i.e., company number, vehicle year and make, etc.).
2. Record of inspections, repairs, and maintenance, including their nature and the date performed, and lubrication records.
3. A preventive maintenance scheduled indicating the nature and date of the various inspection and maintenance operations to be performed.

Every driver must perform a post-trip inspection and complete a written vehicle inspection report at the end of each work day on each vehicle operated, covering at least the parts and accessories previously listed on pages 111-112 (items 1 through 8), plus all wheels and rims and emergency equipment.

The vehicle inspection report shall identify the vehicle and list any defect that would affect its safe operation or result in mechanical breakdown. In all cases, the driver shall complete and sign this report.

Before dispatching the vehicle, the motor carrier shall certify on the report that the defect has been corrected or that correction is unnecessary. This report shall be kept for three months.

Before driving it, the driver shall be satisfied that the vehicle is in safe operating condition and review the last inspection report. If defects were previously noted, the driver must sign the report acknowledging review and the carrier's certification that the required repairs were made.

NOTE: Motor Carriers operating only one motor vehicle are not required to complete a daily vehicle inspection report.
---

Vehicles inspected by enforcement officers that do not meet certain safety criteria by reason of their unsafe mechanical condition or loading which could likely cause a crash or a breakdown, may be placed Out-Of-Service (OOS) until repairs have been made.

## G. PART 397 - TRANSPORTATION OF HAZARDOUS MATERIALS (Haz-Mat) - DRIVING AND PARKING RULES

In general, this part applies to the transportation of Haz-Mat by a CMV that must be marked or placarded in accordance with the "Federal Hazardous Materials Regulations, Part 177.823."

With some limited exceptions, a CMV "which contains Division 1.1, 1.2, or 1.3 explosives shall be attended at all times by the driver or other qualified representative of the motor carrier that operates it." (FMCSR, Part 397.5)



CMV's containing "Division 1.1, 1.2, or 1.3 materials must not be parked on or within five feet of the traveled portion of a public street or highway, or on private property (including premises of a fueling or eating facility) without the knowledge and consent of the person who is in charge of the property and who is aware of the nature of the hazardous materials the vehicle contains." (FMCSR, Part 397.7)

"A motor vehicle which contains hazardous materials other than Division 1.1, 1.2, or 1.3 materials must not be parked on or within five feet of the traveled portion of public street or highway except for brief periods when the necessities of operation require the vehicle to be parked and make it impractical to park the vehicle in any other location." (FMCSR, Part 397.7)

**Unless there is no practical alternative, a CMV containing Haz-Mat must not be operated:**

1. Over routes that go through or near heavily populated areas.
2. Places where groups are assembled.
3. Tunnels.
4. Narrow streets, or
5. Alleys.

Operating convenience is not a consideration.

**CMV's must not be operated near or parked within 300 feet of an open fire. No person may smoke or carry a lighted cigarette, cigar, or other tobacco product on or within 25 feet of a CMV containing certain specified Haz-Mat, or empty tanks that have been used to transport flammable liquids.**

**When re-fueling, the engine of a CMV must not be running and a person shall properly control the fueling process.**

**The driver of any CMV that contains Haz-Mat equipped with dual tires on any axle is required to inspect them as follows:**

- At the beginning of each trip, and
- Each time the vehicle is parked

**Unsafe or overheated tires shall be repaired or replaced immediately.**

**Drivers of CMV's containing Division 1.1, 1.2, or 1.3 explosives are required to possess:**

- A copy of *FMCSR, Part 397*
- Instructions in the event of an accident or delay
- Proper shipping papers
- A written route plan

## **CHAPTER XXI**

### **ALCOHOL AND DRUG TESTING REGULATIONS**

#### **A. WHO MUST BE TESTED**

The Federal Motor Carrier Safety Administration (FMCSA) has adopted controlled substance and alcohol-testing requirements for drivers required to have a CDL. The rule covers both interstate and intrastate truck and motor coach operations, including those operated by:

- Federal, State, local and tribal governments
- Church and civic organizations
- Farmers, and custom harvesters (unless exempt)
- Apiary industries (transportation of bees)
- For-hire and private companies

#### **B. CONTROLLED SUBSTANCES**

The regulations require urine specimens to be analyzed for the following drugs:

- Cocaine
- Opiates
- Marijuana
- Amphetamines
- Phencyclidine (PCP)

## **C. TESTS REQUIRED**

The following drug and alcohol tests apply to employee drivers and contract drivers that a motor carrier intends to use:

- Pre-employment
- Post-crash
- Reasonable suspicion
- Random
- Return-to-duty
- Follow-up

Pre-employment testing does not include testing for alcohol.

## **D. CONSEQUENCES**

Drivers who engage in prohibited alcohol conduct must be immediately removed from safety-sensitive functions. Drivers who have engaged in alcohol misuse cannot return to safety-sensitive duties until they have been evaluated by a substance abuse professional (SAP), and complied with any treatment recommendations to assist them with an alcohol problem.

As with an alcohol misuse violation, a driver will be removed from safety-sensitive duty if he/she has a positive drug test result. The removal cannot take place until the Medical Review Officer (MRO) has interviewed the driver, and determined that the positive drug test resulted from the unauthorized use of a controlled substance. A driver cannot be returned to safety-sensitive duties until they have been evaluated by an SAP, or a MRO has complied with recommended rehabilitation, and has a negative result on a return-to-duty drug test.

## **E. ASSISTANCE FOR SMALL CARRIERS AND OWNER-OPERATORS**

Small motor carriers and owner-operators may find it easier to comply with the regulations by forming a consortium of similar operators to administer or develop and implement a program for the group as a whole. The Maryland Motor Truck Association has information regarding the participation in a group program. If you have questions regarding participating in such a program, call the Maryland Motor Truck Association at 410-644-4600.

## **F. ADDITIONAL INFORMATION**

Contact the USDOT Drug Enforcement and Program Compliance Office at 202-366-3784.

## **APPENDIX- A**

### **GLOSSARY**

**Apportionable Vehicle:** Any vehicle used or intended for use in Maryland and one or more International Registration Plan (IRP) member jurisdictions that allocates or proportionally registers a vehicle and/or vehicles that are used for the transportation of persons for hire, or designed, used or maintained primarily for the transportation of property.

**Axle Weight:** The weight transmitted to the road surface by one axle, or a combination of axles.

**Base Jurisdiction:** For purposes of single vehicle and/or fleet registration, the jurisdiction where the registrant has an established place of business, where mileage is accrued by the fleet, and where operational records of such fleet are maintained or can be made available.

**Base Plate:** The registration/license plate issued by the base jurisdiction and the registration plate issued for the vehicle by any member jurisdiction.

**Cab Card:** Terminology includes:

1. A vehicle registration card issued only by the base jurisdiction for a vehicle of an apportioned vehicle or fleet which identifies:
  - a) The vehicle, and
  - b) Base registration/license plate, and
  - c) Registered weight reflecting the jurisdictions where the vehicle is properly registered.
2. An IFTA license cab card.

**CDL:** Commercial Driver's License.

**CFR:** "Code of Federal Regulations."

**COMAR:** "Code of Maryland Regulations."

**Combination:** Consists of a power unit operating in combination with other vehicles. This includes trailers, semi-trailers and any other vehicle.

### **Commercial Motor Vehicle (CMV):**

**For a Commercial Driver's License (CDL) a CMV means:**

- A motor vehicle or combination of motor vehicles used to transport passengers or property that:
  1. Has a gross combination weight rating (GCWR) of **26,001 or more pounds** and towing a trailer, or semi-trailer that has a gross vehicle weight rating (GVWR) over 10,000 pounds, or
  2. Has a GVWR of 26,001 or more pounds, or
  3. Is designed to transport **16 or more passengers, including the driver**, or
  4. Is of any size and is used in the transportation of materials found to be hazardous for the purposes of the "*Hazardous Materials Transportation Act*," and which requires the motor vehicle to be placarded under the "*Hazardous Materials Regulations*."

**For all other regulations, a CMV means:**

- A motor vehicle or combination of motor vehicles used to transport passengers or property that:
  1. Has a GVWR or GCWR, or gross vehicle weight (GVW) or gross combination weight (GCW) of 10,001 pounds or more, whichever is greater; or
  2. Is designed or used to transport more than **8 passengers (including the driver), for compensation; or**
  3. Is designed or used to transport more than **15 passengers (including the driver), and is not used to transport passengers for compensation; or**
  4. Is used to transport hazardous materials in a quantity that requires placarding.

**Credentials:** Terminology can include/mean, but is not limited to:

- The apportioned registration card and license plate issued for vehicles registered under the International Registration Plan (IRP)
- Registration card and license plate for non-IRP registrants
- IRP Temporary Trip Permit
- A CDL, or non-CDL, or temporary learner's permit
- International Fuel Tax Agreement (IFTA) decal along with corresponding cab card, or copy of an IFTA card
- Temporary IFTA Trip Permit
- Oversize/Overweight Hauling Permit
- Public Service Commission operating authority
- USDOT Number issued by FMCSA
- Maryland intrastate USDOT Number
- Motor Carrier (MC) Number issued by FMCSA
- Hazardous Waste Permit
- Alcoholic Beverage Transportation Permit

**CVISN:** Commercial Vehicle Information Systems and Networks.

**CVSA:** Commercial Vehicle Safety Alliance.

**Decal:** Terminology can include/mean, but is not limited to:

- An International Fuel Tax Agreement (IFTA) numbered sticker which is applied to both sides of a qualifying vehicle. See IFTA reference in this section.
- A Commercial Vehicle Safety Alliance (CVSA) safety sticker applied to a power unit after it has successfully passed a Level I North American Standard Inspection.

**Double-Bottom Combination:** (Doubles) A vehicle combination consisting of a power unit pulling:

- Two (2) semi-trailers, or
- A semi-trailer and a full trailer.

**ES:** Electronic Screening, or E-Screening. A component of CVISN.

**Established Place of Business:** A physical structure (building) located within the base jurisdiction that is designated by a street number (address) and is owned, leased or rented by a fleet registrant. The place of business must be open for business and shall be staffed during regular business hours by one or more persons employed by the applicant or registrant on a permanent basis for the purpose of the general management of the applicant's or registrant's trucking-related business.

**FHWA:** Federal Highway Administration, part of the U.S. Department of Transportation.

**Fleet:** A group of vehicles owned or operated as a unit.

**FMCSA:** Federal Motor Carrier Safety Administration, part of the U.S. Department of Transportation.

**FMCSR:** "Federal Motor Carrier Safety Regulations."

**Freight Trailer or Semi-trailer:** See Trailers.

**Full Trailer:** See Trailers.

**Gross Combination Weight (GCW):** The weight of the power unit, and any other vehicle operated in combination with the power unit including any load carried by the vehicles.

**Gross Combination Weight Rating (GCWR):** The value specified by the manufacturer as the maximum loaded weight capacity of a combination (articulated) motor vehicle. In the absence of a value specified by the manufacturer, the GCWR will be determined by adding the GVWR of the power unit, and the total weight of the towed unit, including any load thereon.

**Gross Vehicle Weight (GVW):** The weight of the vehicle plus the weight of any load thereon.

**Gross Vehicle Weight Rating (GVWR):** The value specified by the manufacturer as the maximum loaded weight capacity of a single vehicle. The manufacturer usually places this information on a label inside the driver's door (check around the door frame after opening the door).

**ITS/CVO:** Intelligent Transportation Systems/Commercial Vehicle Operations.

**International Fuel Tax Agreement (IFTA):** An agreement between Maryland, other states, and specific Canadian provinces for prorating fuel tax fees based on the percentage of fuel used in correlation to miles traveled by a vehicle in each jurisdiction. The District of Columbia does not participate in IFTA.

**International Registration Plan (IRP):** An agreement between Maryland, other states, the District of Columbia, and Canadian provinces for prorating fees between jurisdictions based on percentage of miles traveled by a fleet in each jurisdiction.

**Interstate Operations:** Pick-up or delivery of cargo originating or destined outside the State of Maryland (pier freight, air freight, etc.). Some warehouse freight can be interstate cargo.

**Intrastate Operation:** Pick-up or delivery of cargo originating and destined within the State of Maryland.

**Jurisdiction:** The territorial range over which an authority extends. The term includes but is not limited to a country, federal district of a country, state, county, province, territory, or possession.

**Maxi-cube:** A non-articulating straight truck operated in combination with:

- A semi-trailer which does not exceed 34 feet and is designed to be loaded through the semi-trailer, or
- A trailer which does not exceed 28 feet and is designed so that the truck cargo is loaded through the trailer

**MDE:** Maryland Department of the Environment.

**MDOT:** Maryland Department of Transportation.

**MDTA:** Maryland Transportation Authority, a modal administration under the Maryland Department of Transportation.

**MDTAP:** Maryland Transportation Authority Police.

**MDTAP/CVSU:** Maryland Transportation Authority Police, Commercial Vehicle Safety Unit.

**MPA:** Maryland Port Administration, a modal administration under the Maryland Department of Transportation.

**MSP:** Maryland State Police.

**MSP/ASED:** Maryland State Police, Automotive Safety Enforcement Division.

**MSP/CVED:** Maryland State Police, Commercial Vehicle Enforcement Division.

**MVA:** The Motor Vehicle Administration, a modal administration under the Maryland Department of Transportation.

**Member Jurisdiction:** A state, or states, the District of Columbia\* and Provinces of Canada which are members of the International Registration Plan (IRP) and the International Fuel Tax Agreement (IFTA). **\*The District of Columbia does not participate in IFTA.**

**Motor Carrier:** An individual, partnership, corporation, or other public or private entity engaged in the transportation of goods or persons.

**Motor Carrier Number or MC Number:** Number issued to interstate for-hire carriers by the FMCSA.

**Non-freight Trailer or Semi-trailer:** See Trailers.

**Operational Records:** Documents supporting miles traveled in each jurisdiction and total miles traveled such as fuel reports, trip sheets and logs.

**OOS:** Out-Of-Service.

**Permit:** In common usage, the written authority issued by a jurisdiction allowing specified operation. In IRP states, a Trip Permit is a temporary permit issued by a jurisdiction to a motor carrier registered in another jurisdiction in lieu of regular apportioned registration. Other temporary permits issued for varying lengths of time include Oversize/Overweight Hauling Permits, Temporary IFTA Permits, Hazardous Waste Permits and others which are not listed here.

**PSC:** Maryland Public Service Commission.

**Registrant:** A person in whose name a vehicle is properly registered.

**Registration Year:** The twelve month period during which the registration plates issued by the base jurisdiction are valid according to the laws of that jurisdiction.

**Restricted Plate:** A plate that has time restriction (3 month, 6 month, partial year), geographic area, mileage or commodity restrictions (farm, log or dealer plates).

**SAE:** Society of Automotive Engineers.

**Semi-trailer:** See Trailers.

**SHA:** State Highway Administration, a modal administration under the Maryland Department of Transportation.

**SHA/HPU:** State Highway Administration, Hauling Permits Unit.

**SHA/MCD:** State Highway Administration, Motor Carrier Division.

**Stinger-Steer Automobile Transporter:** A truck tractor-semi-trailer combination designed for and used only to transport automobiles or boats. The fifth wheel is on a drop frame behind and below the rear axle of the power unit.

## Trailers:

**Freight Trailer** - A freight trailer or semi-trailer shall be:

- (1) Designed for towing by a Class "E" truck Class "F" truck tractor; and
- (2) Is in excess of 20,000 pounds gross weight if towed by a Class "E" truck; or
- (3) Is in excess of 10,000 pounds gross weight if towed by a Class "F" truck tractor.

**Full Trailer** - A vehicle without motive power, designed for:

- (1) Carrying persons or property; and
- (2) For being drawn by a motor vehicle; and
- (3) Is so constructed that no part of its weight or load rests upon or is carried by the towing vehicle.

**Non-Freight Trailer** - A vehicle designed for:

- (1) Towing by a Class "A" passenger vehicle, or Class "M" multipurpose vehicle, and
  - Has a gross weight of 10,000 pounds or less, and is a:
    - a. Boat trailer; or
    - b. Camping trailer; or
    - c. Travel trailer; or
    - d. House trailer; or
    - e. Utility trailer.
- (2) Towing by a Class "E" truck, and
  - Has a gross weight of 20,000 pounds or less

**Semi-trailer** - A vehicle without motive power designed for:

- (1) Carrying persons or property; and
- (2) For being drawn by a motor vehicle; and
- (3) So constructed that part of its weight and that of its load rests upon or is carried by the towing vehicle.

**Trip Permit:** See Permit.

**TWIC:** Transportation Worker Identification Credential.

**TWIS:** Truck Weigh and Inspection Stations operated by either the MSP/CVED, or MDTAP/CVSU.

**UCRA:** "Unified Carrier Registration Act."

**USDOT Number:** United States Department of Transportation (USDOT) Number, issued by the Federal Motor Carrier Safety Administration (FMCSA).

## APPENDIX - B

### EMERGENCIES

#### TELEPHONE NUMBERS FOR AGENCIES

1. Local Police, Fire Department – 24 hours  
**911**

To report emergency traffic situations (i.e., accidents, disabled vehicles, drunk drivers, road debris, etc.) from a cellular telephone: dial **#77**

2. Maryland Department of the Environment  
(MDE)

Hazardous Material Spill and Oil Spill  
Response (24 hour)

**1-866-633-4686**

**Division of Radiation Control**  
(Monday through Friday  
7:30 AM - 5:00 PM)

**410-537-3300**

(Monday through Friday,  
including weekends and  
holidays - 4:30 PM - 8:30 AM)

**1-866-633-4686**

3. **Maryland State Police HQ/State Fire Marshal** (MSP monitors CB Channel 9)

**410-486-3101**

Toll-free - Emergencies

**1-800-525-5555**

4. **Maryland Transportation Authority Police (MDTAP)** - MDTAP monitors CB Channel 3

**1-888-754-0185**

5. **National Information Reporting & Response Center** (USDOT)

**1-800-424-8802**

6. **Chemical Transportation Emergency Center** (CHEMTREC)

**1-800-424-9300**

7. **CSX Railroad Grade Crossing**

**1-800-232-0144**

8. **Norfolk Southern Railroad Grade Crossing**

**1-800-453-2530**

9. **Maryland State Highway Administration**  
**Motor Carrier Division**  
**Hauling Permits Unit**

**Emergency Hauling Permits – Non-business hours**

**Statewide Operations Center (SOC)**

**1-800-543-2515**

## APPENDIX - C

### GENERAL CONTACT INFORMATION FOR AGENCIES

The office hours for the below listed agencies in most cases are from 8:00 AM to 5:00 PM, Monday through Friday.

**1. Motor Vehicle Administration (MVA)**

Headquarters  
6601 Ritchie Highway  
Glen Burnie, MD. 21062

Website: <http://www.mva.maryland.gov>

**General Information:**

Toll-free only from MD, DC and Northern VA  
**1-800-950-1682**

From other areas: **1-301-729-4550**

Recorded information and answers to common questions available at other times, 24 hours/day:

**Motor Carrier Services Section,**  
Room 120, Apportioned Registration

Maryland calls only  
**1-800-248-4160**

Calling from outside of Maryland  
**1-410-787-2971**

**Truck and Bus Driver Licensing (CDL)  
Information:**

Maryland calls only  
**1-800-344-7309**

Maryland, DC and Northern Virginia  
**1-800-950-1682**

Calling from outside of Maryland  
**1-301-729-4550**

**2. Office of Freight and Multimodalism**

Maryland Department of Transportation  
7201 Corporate Center Drive  
P.O. Box 548  
Hanover, MD. 21075

**410-865-1094**

Website: <http://www.mdot.maryland.gov/ofm/freight>

**3. Maryland State Highway Administration**

Office of Traffic and Safety  
Motor Carrier Division  
7491 Connelley Drive  
Hanover, MD. 21076

Website: <http://www.roads.maryland.gov>

Email: [MdMotorCarrier@sha.state.md.us](mailto:MdMotorCarrier@sha.state.md.us)

For questions regarding Commercial Vehicle Regulations,  
Safety Programs, ITS/CVO Programs,  
*Maryland Motor Carrier Handbook*, and  
Maryland Truckers Map:

Within Maryland only:

**1-800-543-4564**

Outside Maryland:

**410-582-5734**

Calls for Oversize/Overweight Hauling Permits  
and size & weight issues:

**410-582-5734**

**Emergency Permits Non-Business Hours:  
Call the State-wide Operations Center (SOC)  
1-800-543-2515**

**4. Maryland State Police (MSP)**

Commercial Vehicle Enforcement Division (CVED)  
901 Elkridge Landing Road  
Suite 300  
Linthicum Heights, MD. 21090

MSP Website: <http://www.mdsp.org>

**410-694-6100**

Automotive Safety Enforcement Division (ASED)  
6601 Ritchie Highway  
Glen Burnie, MD. 21062

**410-768-7388**

**5. Maryland Transportation Authority Police**

Commercial Vehicle Safety Unit  
15 Turnpike Drive  
Perryville, MD. 21903-2219

Website: <http://www.mdt.maryland.gov>

**410-537-1126**

**410-537-1128 (fax)**

Baltimore Harbor Tunnel (I-895)

**410-537-1230**

Fort McHenry Tunnel (I-95)

**410-537-1230**

John F. Kennedy Highway (I-95) (MSP)

**410-537-1150**

Nice Memorial Bridge (US 301)

**310-259-4444**

Lane Memorial Bridge (US 50)

**410-537-6601**

Francis Scott Key Bridge (I-695)

**410-537-7600**

Hatem Memorial Bridge (US 40)

**410-537-1196**

**6. Comptroller of Maryland**

Motor-fuel, Alcohol and Tobacco Tax Unit  
(MATT)

P.O. Box 2397

Annapolis, MD. 21404-2397

Website: <http://www.comp.state.md.us>

**For Alcohol Beverage Transportation Permits:**

**410-260-7980**

**For IFTA Decals/Registration:**

**410-260-7980**

Or

**Toll-free calls within Maryland only**

**1-888-638-2937**

**7. Public Service Commission**

Transportation Division

6 St. Paul Street

Baltimore, MD. 21230

Website: <http://www.psc.state.md.us>

**410-767-8128**

- 8. Maryland Department of Environment**  
1800 Washington Blvd. - STE 645  
Baltimore, MD. 21230

Website: <http://www.mde.state.md.us>

**Hazardous Materials Transportation  
Emergency Response Division:**  
**410-537-3975**

**Oil Control Program:**  
**410-537-3442**

**Hazardous Waste Permits and  
Hazardous Materials Information:**  
**410-537-3975**

**Waste Minimization & Recycling (Tires):**  
**410-537-3315**

- 9. Maryland Port Administration**  
2700 Broening Highway  
Dundalk Marine Terminal  
Intermodal Department  
Baltimore, MD. 21222

Website: <http://www.mpa.maryland.gov>

**1-800-638-7519 (Toll-Free)**

- 10. The Maryland Motor Truck Association**  
3000 Washington Boulevard  
Baltimore, MD. 21230

Website: <http://www.mmtanet.com>

**410-644-4600**

**11. The Maryland Motor Coach Association**  
**410-379-0917**

**12. Federal Motor Carrier Safety Administration**  
1200 New Jersey Avenue, SE  
Washington, DC 20590

Website: <http://www.fmcsa.dot.gov>

To Obtain a:

- **USDOT Identification Number**
- Carrier Safety Profile
- Other Federal Safety Information

**1-800-832-5660**

Information for:

- **Operating Authority – For-Hire Carriers**
- New Applications
- Insurance Filing Information
- Safety Ratings

**1-800-832-5660**

Household Goods/Driver Complaints:

**1-888-DOT-SAFT (1-888-368-7238)**

Insurance Information:

**202-385-2423**

**Baltimore Division Office, FMCSA**  
City Crescent Building  
10 South Howard Street, Suite 2710  
Baltimore, MD. 21201

**410-962-2889**